

# ***AIR Industrial***

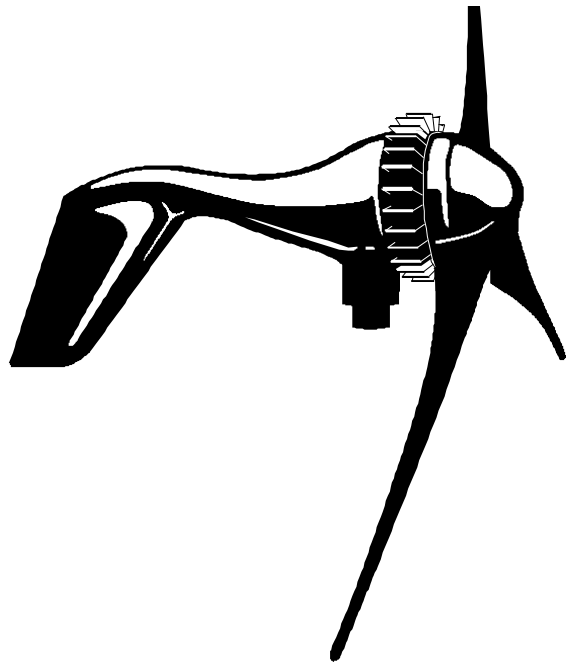

## ***Owner's Manual***

*For AIR Industrial with  
Internal Charge Regulator*

**NOTICES:**

- This information is believed to be reliable; however, Southwest Windpower, Inc assumes no responsibility for inaccuracies or omissions. **The user of this information and product assumes full responsibility and risk.**
- All specifications are subject to change without notice.
- Wind generators, like other sources of electrical power, must be installed following the guidelines established by the National Electrical Code & local regulations. Consult a local electrical contractor for details and regulations.

*Made in the USA by:*

Southwest Windpower, Inc.  
1801 W. Route 66  
Flagstaff, Arizona 86001

Phone: (928) 779-9463  
Fax: (928) 779-1485  
E-mail: [info@windenergy.com](mailto:info@windenergy.com)  
Web: [www.windenergy.com](http://www.windenergy.com)

***AIR Industrial*** is a trademark of Southwest Windpower  
© 1998 Southwest Windpower, Inc.



## CONGRATULATIONS!

You have just purchased the most advanced small wind turbine in the world!

If you have any further questions after reading the manual thoroughly, please contact your authorized distributor/dealer or Southwest Windpower, Inc.

Southwest Windpower has over 12 years of experience in designing and manufacturing small wind generators. In just three years, over 17,000 **AIRs** have been sold throughout the world.

We believe you will find it easy to install your **AIR Industrial**; however, it is important that you read this manual thoroughly prior to installation to assure proper performance and safety.

What makes the **AIR Industrial** unique in comparison to other turbines is the use of state-of-the-art technology like Iron Boron Neodymium magnets, carbon reinforced engineering thermoplastics, high-quality aluminum, all stainless steel hardware and integrated electronics. The turbines come standard with built-in regulators, self-governing mechanisms and the best global warranty program in the industry. A complete list of features is available in [Section 4.1.5 on page 20](#).

Enjoy.

**I. Installation**

**1. Safety Precautions**..... 5  
     1.1 Mechanical Hazards..... 5  
     1.2 Electrical Hazards..... 5  
     1.3 Installation..... 6  
     1.4 Operation..... 6  
**2. Package Contents**..... 7  
**3. Wiring and Installation Procedures**..... 8  
     **3.1 Wiring**..... 8  
         3.1.1 Electrical Connections..... 8  
         3.1.2 Wire Size..... 9  
         3.1.3 Grounding..... 10  
         3.1.4 Fusing..... 10  
         3.1.5 Stop Switch..... 11  
         3.1.6 System Wiring Diagrams..... 11  
     **3.2 Mounting to Tower**..... 14  
         3.2.1 Attaching to Pole..... 14  
     **3.3 Hub and Rotor Assembly**..... 15  
         3.3.1 Mounting Blades..... 16  
         3.3.2 Mounting Hub and Rotor..... 17  
         3.3.3 Attaching Nose Cone..... 17  
     **3.4 Step By Step Instructions**..... 17  
**4. Testing**..... 19  
     **4.1 General Discussion of Operation**..... 19  
         4.1.1 Alternator..... 19  
         4.1.2 Regulator..... 19  
         4.1.3 Blades..... 19  
         4.1.4 Four Spinning Conditions..... 19  
         4.1.5 Industrial Features..... 20  
     **4.2 Bench Testing**..... 21  
     **4.3 Performance Testing**..... 22  
     **4.4 Adjusting the Potentiometer (regulator)** ..... 22  
**5. Trouble Shooting**..... 23  
     **5.1 Assembly**..... 23  
     **5.2 Electrical System**..... 23  
     **5.3 Elevation** ..... 24  
**6. Warranty Policy**..... 25

**II. Appendix**

**7. Specifications**..... 26  
     7.1 Technical Specifications..... 26  
     7.2 Sphere of Operation..... 27  
     7.3 Exploded View of AIR Industrial..... 27  
**8. Maintenance**..... 28  
**9. System Requirements and Considerations**..... 29  
     9.1 Batteries..... 29  
     9.2 Regulator Options..... 29  
**10. Siting**..... 31  
**11. Towers**..... 33  
     11.1 Towers..... 33  
     11.2 Roof Top Mounting..... 33  
**12. Frequently Asked Questions**..... 35  
**13. Accessories**..... 38  
**14. References** ..... 40

**I. INSTALLATION**

## 1. SAFETY PRECAUTIONS

The **AIR Industrial** has been designed with your safety in mind. However, there are inherent dangers involved with any electrical and/or mechanical equipment.

**Safety must be the primary concern as you plan the location, installation and operation of the wind turbine. At all times be aware of electrical, mechanical and rotor blade hazards.**

### 1.1 Mechanical Hazards

Rotating blades present the most serious mechanical hazard. The **AIR Industrial's** rotor blades are made of very strong thermoplastic. At the tip, the blades may be moving at velocities over 300 miles per hour. At this speed, the tip of a blade is nearly invisible and can cause serious injury. ***Under no circumstances should you install the turbine where a person could come in contact with moving rotor blades.***

**CAUTION:** DO NOT INSTALL THE TURBINE WHERE ANYONE CAN APPROACH THE PATH OF THE BLADES.

### 1.2 Electrical hazard

The **AIR Industrial** is equipped with sophisticated electronics designed to provide protection from electrical dangers. The internal electronics of the **AIR Industrial** prevent open circuit voltages from rising above 23 volts for 12 volt systems or above 45 volts for 24 volt systems.

Heat in wiring systems is often a result of too much current flowing through an undersized wire or a bad connection. It is important to follow the wire sizing chart in [Section 3.1.2 on page 9](#) to insure a safe electrical system.

**CAUTION:** FOLLOW THE WIRE SIZING CHART IN [Section 3.1.2 on page 9](#) TO HELP AVOID THE RISK OF AN ELECTRICAL FIRE.

Batteries can deliver a dangerous amount of current. If a short occurs in the wiring from the batteries, a fire can result. In order to avoid this threat, a properly sized fuse or circuit breaker is required in the lines connecting to the battery. Refer to [Section 3.1.4 on page 10](#) for fuse sizing information.

**CAUTION:** FUSE ALL CONNECTIONS. FOLLOW THE FUSE SIZING GUIDELINES IN [Section 3.1.4 on page 10](#) TO MINIMIZE THE RISK OF AN ELECTRICAL FAILURE.

### 1.3 Installation

**CAUTION:** INSTALLATION PROCEDURES MUST BE PERFORMED AT GROUND LEVEL.

**CAUTION:** MAKE SURE THAT ALL BATTERIES ARE DISCONNECTED THROUGHOUT THE INSTALLATION PROCESS.

**CAUTION:** NEVER INSTALL THE *AIR Industrial* UPSIDE DOWN.

Please follow these precautions during the installation process:

- Choose a calm day.
- THINK SAFETY! Have someone available to help during the installation process.
- Disconnect batteries from turbine wiring.
- Prior to attaching the wires to the battery, tie the wind turbine output lead wires (*positive = red; negative = black*) together near the battery to be sure that the rotor will not spin-up during installation.

**NOTE:** Do not install the blade assembly until the turbine is mounted on the tower.

### 1.4 Operation

Check support structures, blades, and electrical systems on a regular basis.

- The rotor blades are very strong; however, if they come in contact with a solid object, they can break. Use common sense when locating the turbine.
- When performing periodic inspections, or at any time when you must approach the path of the blades, disconnect the power leads from the battery to avoid electrical shock and tie the wind turbine output leads together to stop (*slow down*) the blades from rotating. The turbine can also be shut down through the use of a stop switch. Please refer to [Figure 2 on page 11](#) on how to install a stop switch in your system.

**CAUTION:** NEVER APPROACH THE TURBINE DURING OPERATION.

**USE COMMON SENSE AND PLEASE BE CAREFUL**

## 2. PACKAGE CONTENTS

Compare the parts shown in **Figure 1** with the contents of the box to ensure that the box contains all necessary parts.

**CAUTION:** THE EDGES OF THE ROTOR BLADES ARE SHARP. PLEASE HANDLE WITH CARE.

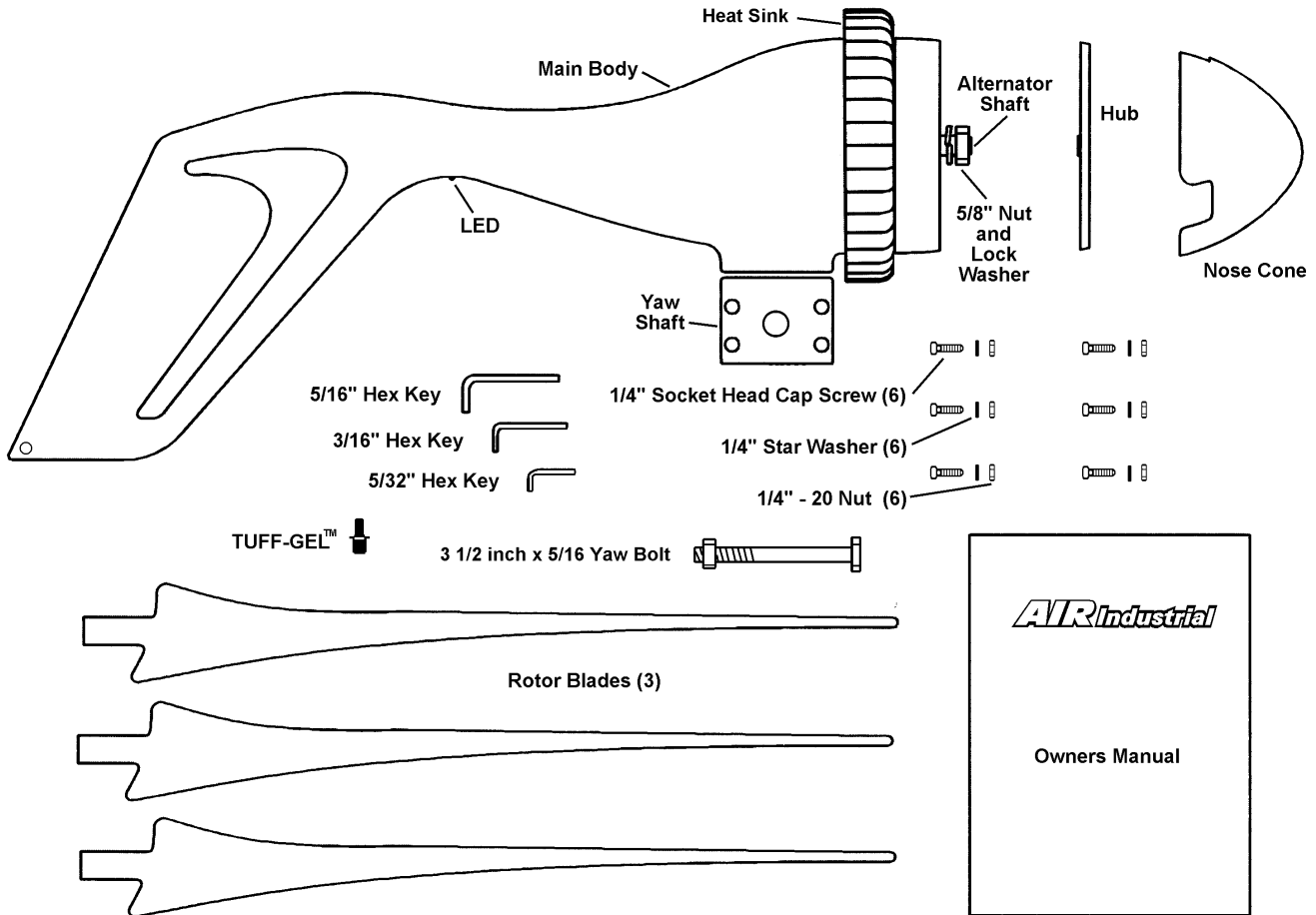

**Figure 1**

### 3. WIRING AND INSTALLATION PROCEDURES

Your **AIR Industrial** is shipped partially disassembled. Refer to **Figure 7 on page 16** for assembly instructions. Read all procedures completely before you begin installing.

**NOTE:** Do not install the blade assembly until the turbine is mounted on the tower.

**Required Tools:**

- 5/16" hex key wrench (*included*)
- 3/16" hex key wrench (*included*)
- 5/32" hex key wrench (*included*)
- Torque wrench with 5/16", 3/16", and 5/32" hex drives
- An adjustable wrench, 15/16" open or box end wrench, or socket wrench.
- Soldering iron or propane torch
- Rosin core solder
- Electrical tape or 1/4" (6-7mm) heat shrink
- Wire strippers
- Wire crimpers

#### 3.1 Wiring

##### 3.1.1 Electrical Connections

**NOTE:** Refer to and apply all Local and National Codes before installation.

**CAUTION:** MAKE SURE THE TURBINE IS DISCONNECTED FROM THE BATTERIES DURING INSTALLATION.

Avoid connecting different metals together (i.e., copper and aluminum). This will cause a galvanic reaction that will lead to a bad connection. When such connections can not be avoided, consult your dealer or an electrical supply house for anti-oxidant compounds. Solder all wire termination ends.

**CAUTION:** CONNECTIONS SHOULD BE INSPECTED PERIODICALLY FOR SIGNS OF CORROSION AND CLEANED WHEN NECESSARY.

**NOTE:** The NEC requires that all electrical power cables be physically protected. Run the wires inside the tower or conduit for maximum protection.

**NOTE:** The yaw can support a total of 150 lbs. (68 kg) in wire weight. For higher wire weights, you must install a strain relief to minimize the stress put on the hanging wires.

**Wire Color Codes**

RED = positive

BLACK = negative

##### 3.1.2 Wire Size

To select the appropriate size wire, measure the distance from the batteries to your **AIR Industrial**, then refer to the following wire sizing chart as *minimum* sizes. A larger sized wire will improve the performance of your system.

This chart is sized for an average 12 mph (6 m/s) wind speed. If the wind speed average in your area is higher, use a larger size wire. Also, the charts below are for copper wire; for other wire types consult the NEC handbook for wire recommendations.

**NOTE:** Battery disconnects may be necessary for compliance with electrical codes.

#### 12v System Wire Size Chart

# Modules	0-75 ft 0-23 m	76-120 ft 24-37 m	121-190 ft 38-58 m	191-300 ft 59-91 m	301-385 ft 92-117 m	386-488 ft 118-149 m
1	#8	#6	#4	#2	#1	#0
<b>(Use above for wiring units individually, use below for wiring BUS systems)</b>						
2	#6	#4	#2	#0	#00	#000
3	#4	#2	#0	#000	#0000	*
4	#2	#1	#00	#0000	*	*
5	#1	#0	#000	*	*	*
6	#0	#00	#0000	*	*	*
7	#00	#000	#0000	*	*	*
8	#000	#000	*	*	*	*
9	#000	#0000	*	*	*	*
10	#0000	#0000	*	*	*	*

#### 24v System Wire Size Chart

# Modules	0-75 ft 0-23 m	76-120 ft 24-37 m	121-190 ft 38-58 m	191-300 ft 59-91 m	301-480 ft 92-146 m	481-765 ft 147-233 m
1	#14	#12	#10	#8	#6	#4
<b>(Use above for wiring units individually, use below for wiring BUS systems)</b>						
2	#12	#10	#8	#6	#4	#2
3	#8	#8	#6	#4	#2	#0
4	#6	#6	#4	#2	#1	#00
5	#4	#4	#4	#2	#0	#000
6	#4	#4	#2	#1	#00	#0000
7	#2	#2	#2	#1	#00	#0000
8	#2	#2	#2	#0	#000	*
9	#1	#1	#1	#00	#0000	*
10	#1	#1	#1	#00	#0000	*

\* If your system requires this length of wire, consider using additional bus line(s)

### 3.1.3 Grounding

As with all systems, properly grounding the turbine is very important in protecting the electronics for long-term operation. Grounding procedures must be followed along with any local grounding codes.

**IMPORTANT: SEVERE TURBINE DAMAGE CAN RESULT FROM IMPROPER GROUNDING! FAILURE TO GROUND PROPERLY WILL VOID YOUR WARRANTY.**

The turbine is internally grounded to the negative wire. As with all systems, it is very important to ground your battery bank and ground your tower for lightning and static protection. All system grounds must be connected together by conductors with the same ratings as the positive and negative wires.

**IMPORTANT: ALL grounds must be connected together to insure a proper ground.**

For land based systems without an existing system ground, a ground electrode can be made from an 8 ft. (2.4 m) section of 3/4" (19 mm) galvanized pipe or conduit, or an 8 ft. (2.4 m) section of 5/8" (16 mm) copper plated iron or steel rod. This ground electrode must be buried completely beneath the soil, at no more than 45 degrees from vertical, or horizontally at least 2 1/2 ft. (75 cm) beneath the surface. It is recommended that the ground electrode be installed as close as possible to the system for maximum lightning protection. The base of the tower is also a good location for an appropriate surge arrestor.

Delta manufactures surge arrestors for lightning protection. An example is the model LA 302-RG surge arrestor. Contact: Delta Lighting Arrestors P.O. Box 750, Big Springs TX 79721, Phone (915) 267-1000 Fax (915) 267-1035 or your dealer for more information.

Most vessels use the engine block or a submerge plate to carry the ground to the water. For installations on vessels the **AIR Industrial** should be grounded according to the *American Boat and Yacht Council (ABYC). Ph. (410) 956-1050*. The reference section in the appendix lists two books that provide detailed information on proper grounding in marine applications.

### 3.1.4 Fusing

The **AIR Industrial** is capable of producing high amperages. As with all electrical installations, you must fuse each of your turbines.

#### *Recommended Circuit Breakers*

- 12-volt model: 50 amps D.C. for each unit
- 24-volt model: 30 amps D.C. for each unit
- 36-volt model: 20 amps D.C. for each unit
- 48-volt model: 15 amps D.C. for each unit

### 3.1.5 Stop Switch

The Stop Switch is a 50 amp D.C. single-pole double-throw switch that is used to shut the turbine off. The switch disconnects the battery and then shorts the turbine causing the turbine to stop spinning (*in high winds the blades will spin slowly*). Shorting the turbine will not cause any damage or additional wear.

Your dealer/distributor should be able to supply the stop switch or you can contact Southwest Windpower directly. They can also be found at most automotive electrical stores.

**NOTE:** The center post must be positive from the turbine. Outside posts can be swapped as either positive or negative.

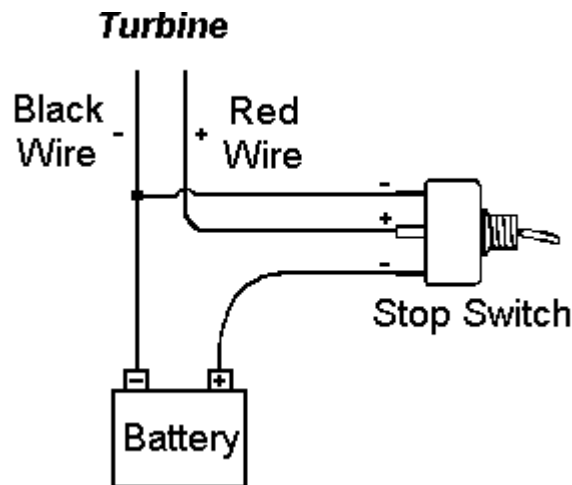

Figure 2 Stop Switch Wiring

### 3.1.6 System Wiring Diagrams

Before deciding on the wiring of your **AIR Industrial**, you should understand how your existing system is wired and how the **AIR Industrial's** internal regulator operates. Refer to the General Discussion of Operation in [Section 4.1.2 on page 19](#) for information on the **AIR Industrial's** internal regulator.

Southwest Windpower recommends wiring the turbine directly to its own set of battery posts on the battery bank. This will allow the turbine to operate independently. The **AIR Industrial's** internal regulator will independently monitor the battery charge state and charge as necessary.

You can wire the **AIR Industrial** through most “power centers”. However, if you experience interference or pre-regulation, you must bypass it and wire the turbine directly to the battery bank.

Some external charging sources (*i.e. solar panels, fuel-powered generators, additional wind generators etc.*) can interfere with the turbine's electronics and cause pre-regulation. External interference will not harm the turbine: it will just cause the turbine to spin slowly as if

it were “braked” or in the stop position. If this occurs, test the possible interference by disconnecting the other charge sources to determine the possible source of interference.

Choose the appropriate wiring diagram below for proper wiring information.

**A. Single AIR Industrial Wiring**

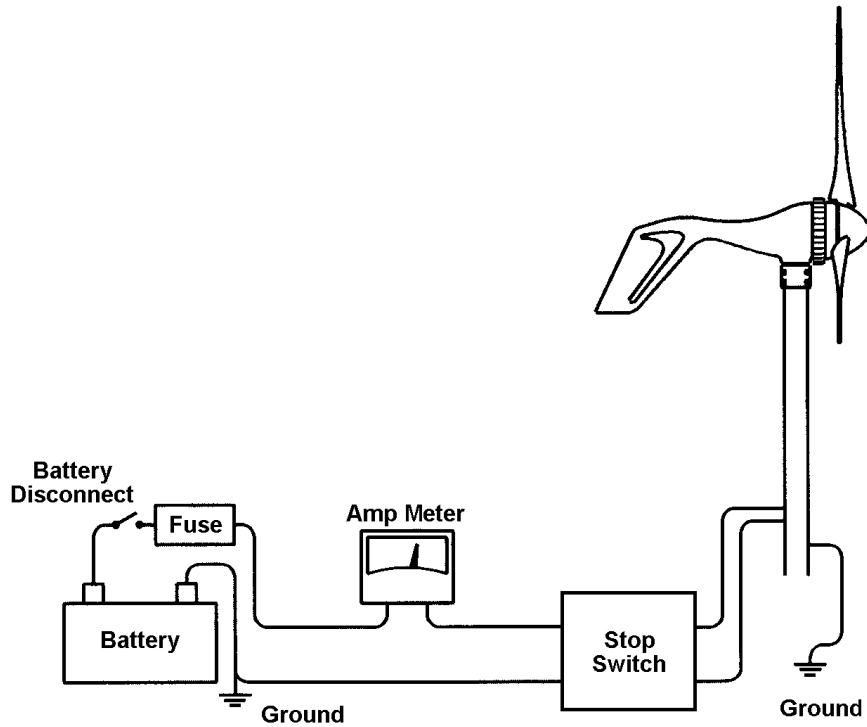

Figure 3

**B. AIR Industrial In A System With Solar Panels (Hybrid System)**

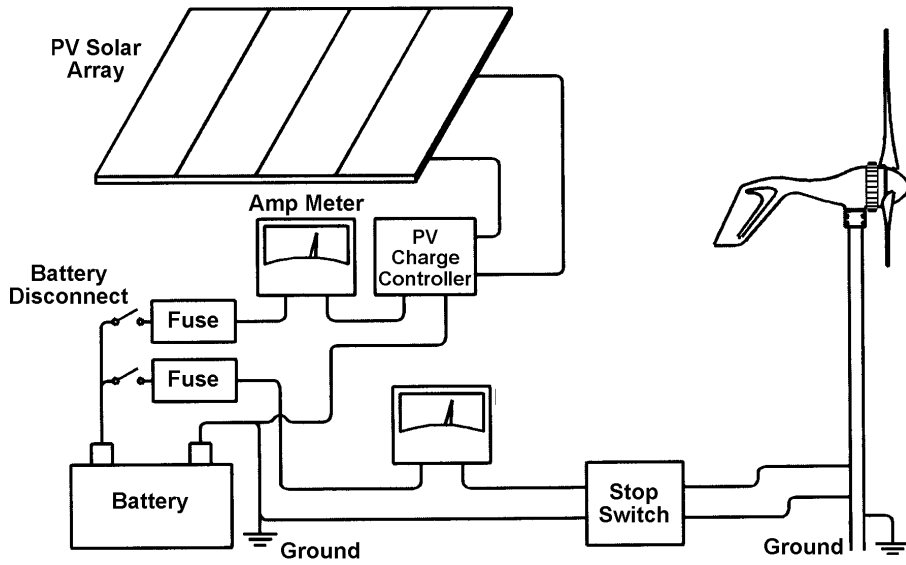

Figure 4

**NOTE:** In this drawing the **AIR Industrial's** internal regulator is used. A diversion type external regulator can also be used.

**C. Multiple AIR Industrial Installation**

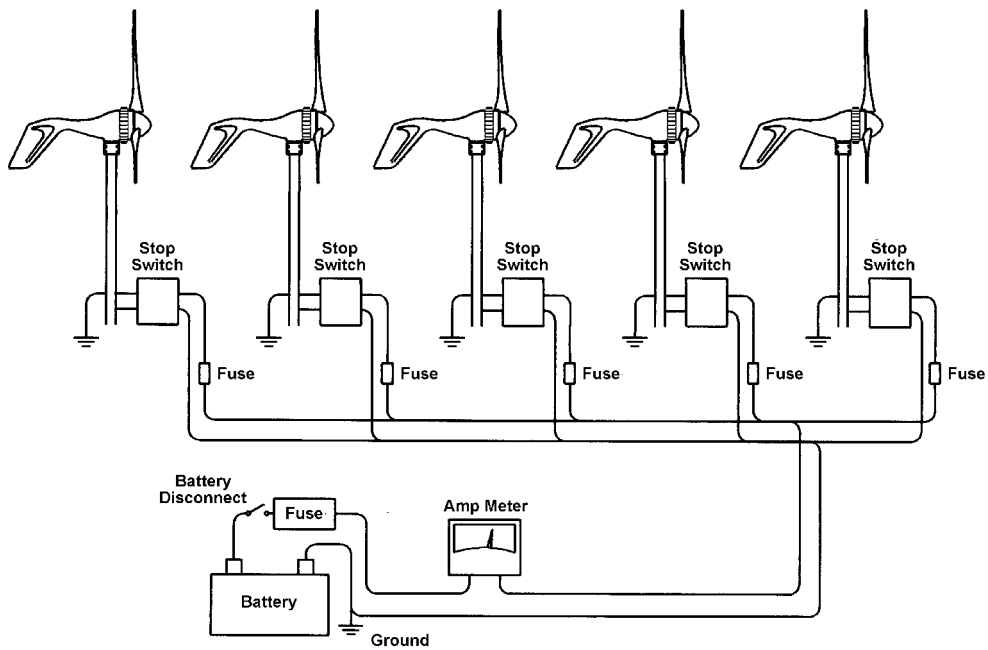

Figure 5

There are two methods to wire multiple **AIR Industrials**.

**a) Each Turbine Wired Directly To Battery**

Each turbine operates as an independent system separate from other solar panels, gas generators or any other battery charging sources. Since the turbine has its own fuse, stop switch (*optional*), and wires, the turbine is able to independently communicate and charge the battery.

**b) Each Turbine Wired To A Bus Bar**

If you plan to wire two or more turbines to a “bus”, and then run one set of wires from the bus to the battery, you can use each turbine’s internal regulator or install an external regulator. If you use an external regulator, use a diversion style regulator that turns excess power into heat for heating a room, water etc. When wiring multiple turbines, a bus bar system can save you money by reducing the wire cost.

### 3.2 Mounting To Tower

The **AIR Industrial** is designed to be mounted on a 1 1/2“, SCH 40 steel or aluminum pipe. The outside diameter of the pipe should be 1.875” (48 mm). There is a soft coupling inside the yaw shaft mount that is designed to provide a secure fit and to dampen the noise transmitted down the tower. The clamp and soft coupling will also accommodate small variations in diameter; however, if you plan to use something other than a 1 1/2“, SCH 40 (48 mm) pipe, be sure to check for a secure fit prior to installation.

**CAUTION: Only use metal pipe for towers. Never use plastic pipe.**

#### 3.2.1 Attaching to Pole

The **AIR Industrial** yaw has a through-bolt to mechanically fasten the yaw to the tower. To properly mount the turbine to the pole please follow the directions below.

- A. Drill a hole through the tower using the diagram below.
- B. Feed system wires through tower and attach to turbine wires.
- C. Slide the yaw all the way down over the end of pole.  
Be sure not to pinch the wires against the top of the pole
- D. Insert 5/16 bolt through yaw and tower.
- E. Securely tighten 4 yaw screws.
- F. Tighten 5/16 yaw bolt.

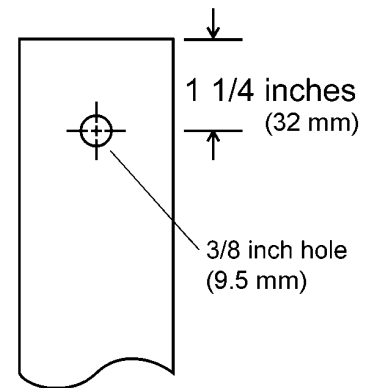

**Note:** While attaching the turbine to the tower, be careful not to pinch the yaw wires. Make sure that your tower allows for proper clearance of the blades. A minimum 2 inch (20 mm) clearance must be given between the blade tips and any obstructions. Refer to [Figure 6](#) below, and the “Sphere of Operation” drawing in [Section 6.2 on page 27](#) for proper clearances.

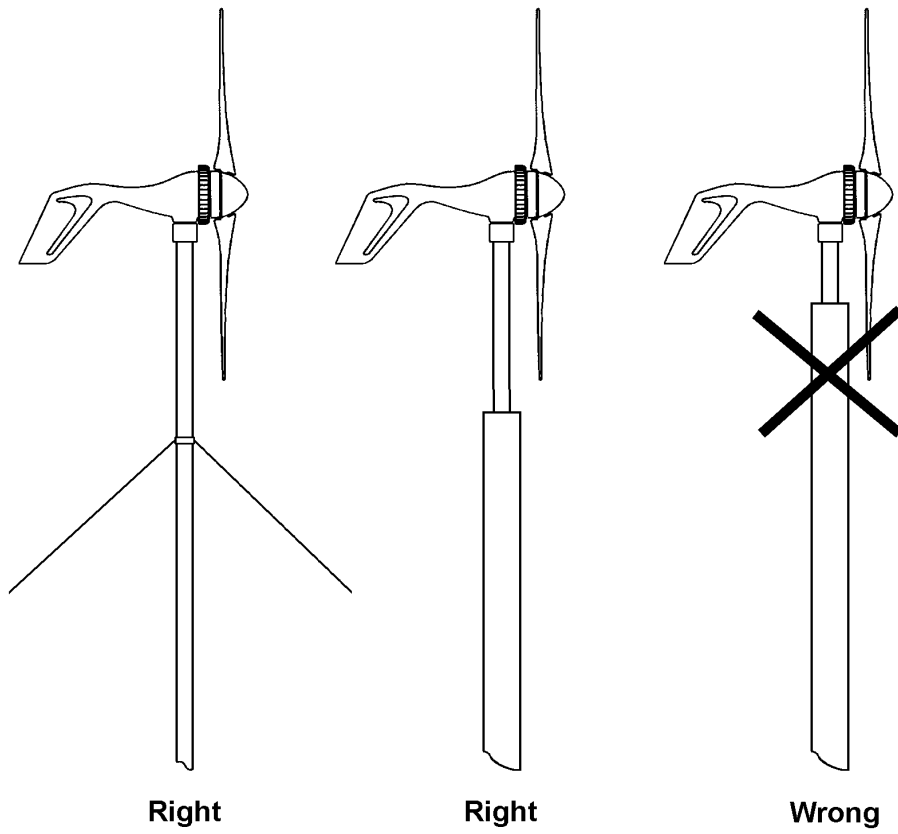
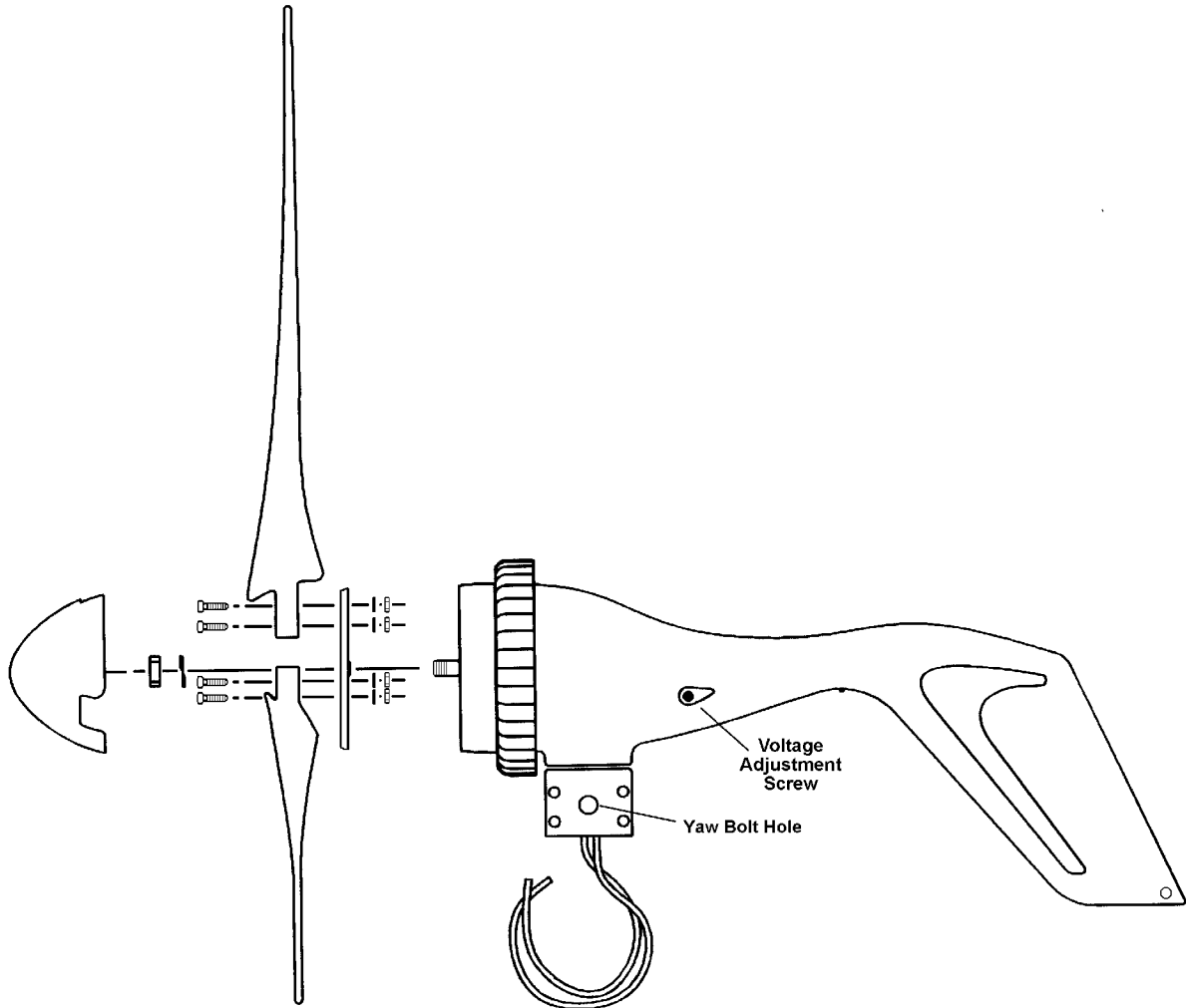

**Figure 6** *Proper Blade-to-Tower Clearances*

### 3.3 Hub And Rotor Assembly

Before assembling the hub and rotor refer to **Figure 7** below, and the following detailed instructions.

**NOTE:** To avoid damage to the blades during installation, do not put the blade assembly on the turbine until the turbine is mounted on the tower.



**Figure 7**

#### 3.3.1 Mounting the Blades

**CAUTION:** THE EDGES OF THE ROTOR BLADES ARE SHARP. PLEASE HANDLE WITH CARE.

Start with the flat surface of the hub facing up. Notice that the screw holes in the blades are counter-bored for the socket head cap screws. Place one of the blades, with the counter bore facing up, on the flat side of the hub and align the screw holes. Insert one of the socket head

cap screws through the blades and hub. Place a small amount of Tef-Gel™ anti-seizing agent on the threads of each screw. Place a star washer and nut on the end of the screw and tighten the screw with the 3/16" hex key wrench to 72 inch lbs. (8.20 Nm). Repeat this procedure on all three blades.

**NOTE:** You may need to "thread" the screws through the hub and blades with the hex wrench.

### **3.3.2 Mounting the Hub and Rotor**

Remove the 5/8" nut and lock washer from the alternator shaft. Carefully slide the blade assembly onto the alternator shaft. Place the split washer on the shaft and thread on the nut. Insert the 5/16" hex key torque wrench into the alternator shaft and tighten the shaft by holding the nut with a wrench and tightening the shaft with the torque wrench. The nut should be tightened to 50 - 65 foot pounds (6800 – 8800 Nm). When the blade set assembly is tightened, spin it to be sure it turns freely.

### **3.3.3 Attaching Nose Cone**

Carefully place the nose cone over the center of the hub and the blades. Snap the nose cone into place. Be sure all three edges catch. Check if the nose cone is on secure by firmly pulling on it.

We recommend you do not install the nose cone at extreme high wind and turbulence sites. The nose cone is cosmetic and does not increase the performance of the turbine. The nose cone can fly off in very high winds and can damage the blades. Leaving the nose cone off will increase reliability without reducing performance.

## **3.4 Step By Step Instructions**

The following *Step-By-Step-Installation-Procedures* is an outline of the **AIR Industrial** installation process. This consolidated reference should only be used as an outline during installation. Refer to the appropriate sections for further details.

1) Run the wires from the battery (do not connect to the battery), through the pole to the top of the tower. **Be sure not to connect the wires to the battery until everything else has been completed.**

2) Strip the insulation back from each set of wires.

3) Mark both ends of all the wires with tape to identify which is negative and positive.

**AIR Industrial** color codes:

RED = Positive

BLACK = Negative

4) Insulate the connections using either heat shrink tubing or a quality electrical tape.

5) Connect the wires from the **AIR Industrial** to the wires running to the battery.

**CAUTION:** IF THE WIRES ARE HOOKED-UP BACKWARDS YOU WILL DAMAGE THE **AIR INDUSTRIAL'S** ELECTRONICS. (IF YOU ARE UNCERTAIN OF THE POLARITY OF THE WIRES, SIMPLY SPIN THE ROTOR SHAFT AND MEASURE THE VOLTAGE DIRECTION WITH A VOLT METER).

- 6) Once the wires are attached to the **AIR Industrial**, gently pull the wires down through the tower sliding the yaw shaft over the 1 1/2", Schedule 40 steel or aluminum pipe (*Actual OD 1.875 inches, 48mm*).
  - 7) Slide the yaw shaft all the way down over the end of pole being careful not to pinch the yaw wires. Be sure to leave enough slack in the wires so that if necessary, the turbine can be removed.
  - 8) Once the yaw shaft is on the tower, firmly tighten the yaw clamp screws with the 5/32 hex key. The **AIR Industrial** should yaw freely without restrictions.
  - 9) Check your **AIR Industrial** to be sure that it is securely attached to the mounts. Remember that this attachment will have to hold in high winds.
  - 10) Attach the assembled hub and blades to the rotor shaft.
  - 11) Run all wires from the turbine to the battery (do not connect wires to the battery). Be sure to crimp and solder the connections using the appropriate sized connectors. If you plan to connect an amp meter into your system, see [Figure 4, on page 12](#).
  - 12) Attach your positive (RED) wire to a fuse. Refer to [Section 3.1.4](#) for fusing information.
  - 13) Make sure that your system is properly grounded before proceeding. Refer to the Grounding [Section 3.1.3 on page 10](#).
- IMPORTANT: SEVERE UNIT DAMAGE WILL RESULT FROM IMPROPER GROUNDING. FAILURE TO PROPERLY GROUND THE TURBINE CAN BE DETECTED AND WILL VOID YOUR WARRANTY.**
- 14) Before attaching the wiring to the battery, make sure that:
    - all circuit breakers are in the off position
    - the stop switch is in the "stop" or shorted position (if installed)
  - 15) Attach wires to the battery. Red wire to positive, Black wire to Negative.
  - 16) Turn on the circuit breakers and/or stop switch.
  - 17) When the blades are rotating very quickly in the wind, you should see the red LED illuminate.
  - 18) You have now completed the installation process.

## **4. TESTING**

### **4.1 General Discussion of Operation**

The available energy in the wind is the cube of the wind speed. This means that each time the wind speed doubles you get eight times the power. The unique design of the **AIR Industrial** is such that it can take full advantage of the power in the wind. The efficiencies of other wind turbines are usually linear and can not take advantage of the wind's cubing effect. These turbines are efficient at only one or two points along their power curve. However, the **AIR Industrial's** efficiency curve matches the available energy in the wind making it efficient all along its curve. This explains why the **AIR Industrial** is able to provide a large amount of power.

#### **4.1.1 Alternator**

The **AIR Industrial** uses a three-phase brushless permanent magnet alternator that internally rectifies the power to D.C. The rotor is comprised of 12 Neodymium Iron Boron magnets, the most powerful magnet material available. These magnets are bonded to the rotor with a high-temperature high strength epoxy and secured with a 5/16" (8 mm) wide stainless steel band. The stator is hand wound for maximum output.

#### **4.1.2 Regulator**

The internal controller is a taper-charge shunt style regulator. As the batteries approach full charge the turbine's output reduces. To check the batteries' charge state, the regulator momentarily stops charging and senses the batteries' voltage to determine whether to continue charging or not. The closer the battery voltage is to the regulation set point, the more frequently the turbine "checks" the battery's voltage. When the battery voltage matches the regulation set point the turbine will "shut off".

#### **4.1.3 Blades**

The blades consist of an injection-molded high strength carbon fiber reinforced thermoplastic resulting in strong lightweight blades. The blades are computer designed to efficiently extract the most power out of the wind. The blade design also provides "over-speed" protection in high winds. All wind generators need some type of high wind over-speed protection. The **AIR Industrial's** blades feature *aeroelastic twist*. In winds moving above approximately 48 mph (21.5 m/s), the blade tips will "dump" excess wind off by twisting. This prevents the turbine from over-speeding. This way the turbine is able to maintain maximum output, providing you with the most possible power and reducing the number of parts, resulting in increased reliability. The only disadvantage of this type of governor is that in high winds the turbine may produce a loud noise. Other turbines have complex mechanisms that either mechanically break the turbine or turn it out of the wind. This can reduce their output by as much as 90%.

#### **4.1.4 Four Spinning Conditions Of the AIR Industrial**

##### **a) Open Circuit**

When the turbine is disconnected from the batteries, it will "free-spin". In this mode the generator can spin "unloaded" with the wind. At approximately 48 mph (21.5 m/s) wind speed, the blades will begin to go into aeroelastic stall to prevent the rotor from over-speeding.

Operating the turbine in open circuit will not damage the turbine. However, we recommend the turbine should either be connected to a battery or the turbine wires should be shorted.

Shorting the turbine will minimize wear to the bearings, prolong the turbine's life and run quieter compared to running open circuit.

**b) Normal Operation (Charge)**

When the generator is connected to a battery bank in need of a charge, the turbine's blades will spin "normally" with the wind. The turbine will charge the batteries as needed until the battery voltage matches the regulation set point.

**NOTE:** When switched from open circuit to charge, you may notice an approximate 10% - 20% reduction in RPM as the generator is now "under load".

**c) Regulation**

When the battery voltage matches the regulation set point, the turbine will go into "regulation". Blade RPM and output will be reduced. *(In high winds there will still be a trickle charge.)*

**d) Braking**

Braking can be accomplished by directly shorting the turbine's negative and positive wires or through the use of a Stop Switch. The Stop Switch will disconnect the turbine from the battery, and then short the positive and negative leads from the generator. The blades could still spin slowly but will not charge the battery.

**4.1.5 Industrial Features**

The **AIR Industrial** is designed for very high wind, high turbulence sites. Every detail of the turbine has been engineered to survive the harshest conditions that the environment can deliver. Below is a description of the major features.

- A. The finned extension adds a substantial amount of cooling for the internal electronics allowing for sustained high outputs. The cooler running turbine will offer higher outputs and increased reliability.
- B. The finned extension also substantially increases the tip-to-tower clearance of the blades. This increase blade tip clearance allows the blades additional room for harsh mountain-top winds.
- C. The yaw of the **AIR Industrial** has been enhanced in following five ways:
  - 1. The yaw wires are 48 inches long for easier installations. These wires are more than 30 inches longer than our standard turbines.
  - 2. The yaw wire is a much heavier wire for better turbine output. The 8 gage wire can handle all of the power that the turbine can produce.
  - 3. A through-bolt has been included to provide a "positive mechanical lock" onto the tower. Even if the yaw bolts are not properly tightened the yaw will be securely attached. This method of fastening will survive any wind condition.
  - 4. The material used to bond the yaw wires, slip rings and yaw body assembly is a high temperature, high strength epoxy. This epoxy can handle over 50 amps of continuous power.

5. The yaw slip ring system has two wires instead of the three found on the standard units. This allows for easier installations. The negative (black) wire is internally grounded. Make sure to properly ground the negative wire on the battery bank to protect your turbine and system.

D. The blades of the **AIR Industrial** are made of a material that is three times as impact resistant than our standard blades. These blades are designed to better withstand flying debris that can accompany high winds. However, the turbine should be installed high enough to avoid flying debris.

E. The **AIR Industrial** does not produce radio interference. This is standard with all of our turbines.

## 4.2 Bench Testing

Two quick bench tests can verify if your **AIR Industrial** is providing output.

### Test 1

1. Remove blade assembly from turbine and place in a safe place. *(Do not stand the blade assembly against a wall.)*
2. Spin rotor shaft with your fingers while at the same time connecting and disconnecting the Red and Black yaw wires.
3. When the yaw wires are connected, the rotor shaft should become more difficult to rotate and feel "lumpy". When the yaw wires are disconnected, it should spin freely. If these conditions do not exist, you should contact your distributor or Southwest Windpower.

### Test 2

1. Remove blade assembly from turbine and place in a safe place. *(Do not stand the blade assembly against a wall.)*
2. Connect a voltmeter across the Red and Black yaw wires.
3. With a 5/16" hex drive in an electric drill, spin the rotor shaft while observing the voltmeter. *(Cut a small piece off of the provided Hex Key if necessary.)*
4. Rated voltage should be obtained at a minimum of 500 RPM.

## 4.3 Performance Test

1. *Isolate the turbine from the system.*  
Connect red positive turbine wire to the battery positive post. Connect the black negative turbine wire to the negative battery post. Make sure no other system

charging components are connected. Also, make sure that switches, diodes, regulators or meters are not connected.

2. *Connect amp meter.*

Connect a non-averaging, analog or digital amp meter in-line with the positive (*red*) wire according to the manufacturer's recommendations.

3. *Monitor wind speed vs. output*

Record the data and compare to the power curve. Use an anemometer located within 5 feet (1.5 m) of the turbine to get accurate wind speed information. An anemometer located in a higher location will not provide correct information for power curve assessment. Small differences in the wind can have substantial effects on output.

4. *Check results*

If the turbine has very poor or no output when compared to the power curve, refer to the Trouble Shooting section.

#### 4.4 Adjusting the Internal Regulator

It is important to understand how to use the **AIR Industrial's** internal electronics to ensure proper charging of your batteries. Refer to **Figure 7 on page 16** for the location of the regulator adjusting screw.

In the following paragraphs 24 volt settings are in *italics*.

The voltage regulator is factory set at 14.1 (*28.2*) volts. The factory setting is marked on the casting with a small indentation aligned with the screw slot.

To change the setting on the voltage regulator, rotate the adjusting screw 1/8 of a turn for each 0.7 (*1.4*) volts change desired. For example, if you want to set your voltage regulator to 14.8 (*29.6*) volts, turn the adjusting screw clockwise by 1/8 turn, from the 14.1 (*28.2*) volt setting.

If the adjustment screw is turned fully clockwise, the regulator will be set at 17.8 (*35.6*) volts. If the adjusting screw is turned fully counterclockwise, the regulator will be set at 13.8 (*27.6*) volts (*Note: If the battery voltage is above the regulation set point the turbine will not charge the batteries.*)

#### **AIR Industrial Adjustable Voltage Range**

<b>12v</b>	13.8v to 17.8v	preset to 14.1v
<b>24v</b>	27.6v to 35.6v	preset to 28.2v
<b>36v</b>	41.4v to 53.4v	preset to 42.3v
<b>48v</b>	55.2v to 71.2v	preset to 56.4v

**NOTE:** Turning "up" the regulation set point adjustment will not increase the **AIR Industrial's** output voltage or amperage. It simply adjusts the "shut down" point of the generator's voltage regulator.

## 5. Trouble Shooting

After following the installation instructions you find your turbine not working properly, read this chapter and carefully compare your installation with each section.

### 5.1 Assembly

Make sure the blade assembly is on tight. You can check by placing the 5/16" hex key in the shaft, holding it and attempting to turn the blade assembly. If you can turn the blade, retighten the blade assembly.

To minimize noise, loosen the four mounting screws and move the turbine up 1/8" inch (2mm) and then re-tighten the screws. This will prevent the top of the pole from touching the hard plastic in the yaw shaft assembly.

### 5.2 Electrical system

Your battery bank should be a *minimum* 400 amp hours for 12v systems, and 200 amp hours for 24v system. If your battery bank is smaller than the recommended size, battery voltage could quickly rise while the turbine is charging and cause the internal regulator to prematurely stop charging. The **AIR Industrial's** trickle charge could potentially over-charge a smaller battery.

Measure the voltage at the battery terminals to which the **AIR Industrial** is connected. **If the voltage for a 12v system reads 14.1 or higher (24v 28.2), the turbine will sense the battery is charged and stop producing power.** (*In high winds there will still be a trickle charge.*)

**NOTE: THE AIR INDUSTRIAL'S ELECTRONICS INCLUDE INTERNAL DIODES. DO NOT PUT ADDITIONAL BLOCKING DIODES BETWEEN THE AIR INDUSTRIAL'S WIRES AND THE BATTERIES. ANY DIODES BETWEEN THE TURBINE AND THE BATTERIES WILL PREVENT THE TURBINE FROM PROPERLY SENSING THE BATTERY VOLTAGE.**

While you are conducting output tests, make sure no other devices such as alternators or photovoltaic panels are charging the batteries at the same time. The total voltage from other charging sources could increase the battery voltage causing the **AIR Industrial's** regulator to think the batteries are charged and prematurely stop charging.

It is wise to connect the wires from the **AIR Industrial** to separate battery terminals on the battery bank to ensure the turbine reads the battery voltage instead of line voltages from other charging sources. Higher input voltages from solar panels can trick the **AIR Industrial** into thinking the battery is charged.

You should also check the condition of each individual battery. One bad cell in a battery can create high voltages (16-18 volts) and stop the turbine from charging. Consult the battery manufacturer for testing individual batteries and cells.

### 5.3 Elevation

An important fact to keep in mind is elevation. The higher a wind generator is from sea level, the lower the air density. Air density is directly proportional to the output of your turbine. Keep this in mind when determining the maximum output that can be expected from a wind turbine when comparing to the published power curve;

1-500 ft	(0 – 150 m)	100%
500-1000 ft	(150 – 300 m)	97%
1000 - 2000 ft	(300 – 600 m)	94%
2000 - 3000 ft	(600 – 900 m)	91%
3000 - 4000 ft	(900 – 1200 m)	88%
4000 - 5000 ft	(1200 – 1500 m)	85%
5000 - 6000 ft	(1500 – 1800 m)	82%
6000 - 7000 ft	(1800 – 2100 m)	79%
7000 - 8000 ft	(2100 – 2400 m)	76%
8000 - 9000 ft	(2400 – 2700 m)	73%
9000 - 10,000 ft	(2700 – 3000 m)	70%

#### **SUMMARY OF TROUBLESHOOTING TIPS:**

- Make sure no diodes are in the line between the **AIR Industrial** and the battery.
- Make sure the amp meter is of the proper type and is hooked up properly
- Digital hand held meters work best for testing. They usually have a 10 or 20 amp DC scale, which is adequate, unless high winds are present.
- Make sure your amp meter is not an averaging style.
- If you are using an external regulator, be sure the adjustment screw on the **AIR Industrial** is turned all the way clockwise.
- Make sure you are measuring the current through the positive wire. If you measure the current through the negative wire, you may only measure part of the current; the other part may travel through the ground connection.
- External regulators should be “diversion load” types.
- Use accurate wind speed information. Small differences in wind speed will have large effects on output.

## **6. WARRANTY POLICY**

### **What Is Covered And For How Long**

Any defective part in turbines that are three years old or less, will be replaced at no charge. A defective part is determined by either a Southwest Windpower, technician, or an Authorized Service center.

### **What Is Not Covered ..... Damage caused by;**

- lightening
- extreme winds (120 MPH+; 60 m/s)
- improper installation (including to but not limited to poor tower design & inverted hanging)
- improperly wiring to batteries
- flying debris resulting in blade damage

### **Limitations And Exclusions**

- 1) No one has the authority to add to or vary this limited warranty, or to create any other obligation in connection to Southwest Windpower and its products.
- 2) ANY IMPLIED WARRANTY APPLICABLE TO SOUTHWEST WINDPOWER'S PRODUCTS IS LIMITED IN DURATION TO THE SAME PERIOD OF TIME AS THIS WRITTEN WARRANTY.
- 3) SOUTHWEST WINDPOWER SHALL NOT BE LIABLE FOR INCIDENTAL, CONSEQUENTIAL SPECIAL, OR CONTINGENT DAMAGES THAT ANY PERSON OR PROPERTY MIGHT SUFFER AS A RESULT OF ITS BREACH TO THIS WRITTEN AND OR IMPLIED WARRANTY.
- 4) This warranty applies to the original purchaser and may be transferred.

### **The Customer's Responsibilities**

All of Southwest Windpower's products must be installed and operated in accordance to the owner's manual and local codes.

You should keep a copy of the invoice or canceled check to verify the purchase date.

### **If You Experience A Problem With Your Southwest Windpower Product**

Contact your nearest authorized service center or Southwest Windpower to determine the nature of the problem.

In case of any problems, either Southwest Windpower or the Authorized Service center will issue a return authorization number for repair of the turbine or send you the replacement parts. You need to put the issued RA number on the outside of the box when you return the unit to Southwest Windpower for repair. Southwest Windpower or the Service Center will repair the turbine within 48 hours and will pay return shipping.

### III. Appendix

#### 7. SPECIFICATIONS

##### 7.1 Technical Specifications

Rotor Diameter:	46 inches (1.14 meters)
Weight:	14 lb. (6.2kg)
Start up wind speed:	7 mph (2.7 m/s)
Rated Power:	300 watts at 28 mph (12.5 m/s)
Regulator Set Range:	12v    13.8v - 17.8v    preset to 14.1v 24v    27.6v - 35.6v    preset to 28.2v 36v    41.4v - 53.4v    preset to 42.3v 48v    55.2v - 71.2v    preset to 56.4v
Recommended Fuse Size:	12v - 50 amps 24v - 30 amps 36v - 20 amps 48v - 15 amps
Yaw Wire Size:	#8 AWG ( <i>American Wire Gage</i> ) stranded.
Pole Dimensions:	1½ Schedule 40 pipe ( <i>outside diameter 1.875 inch, 48mm</i> )
Minimum Battery Bank:	400 amp hours (12v) 200 amp hours (24v)

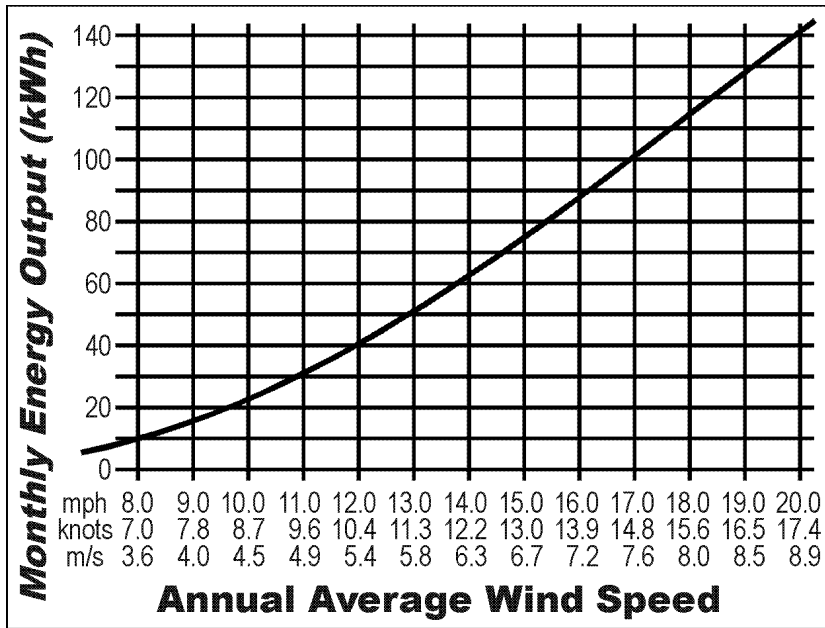

based on Rayleigh Distribution Curve k=2

### 7.2 Sphere of Operation

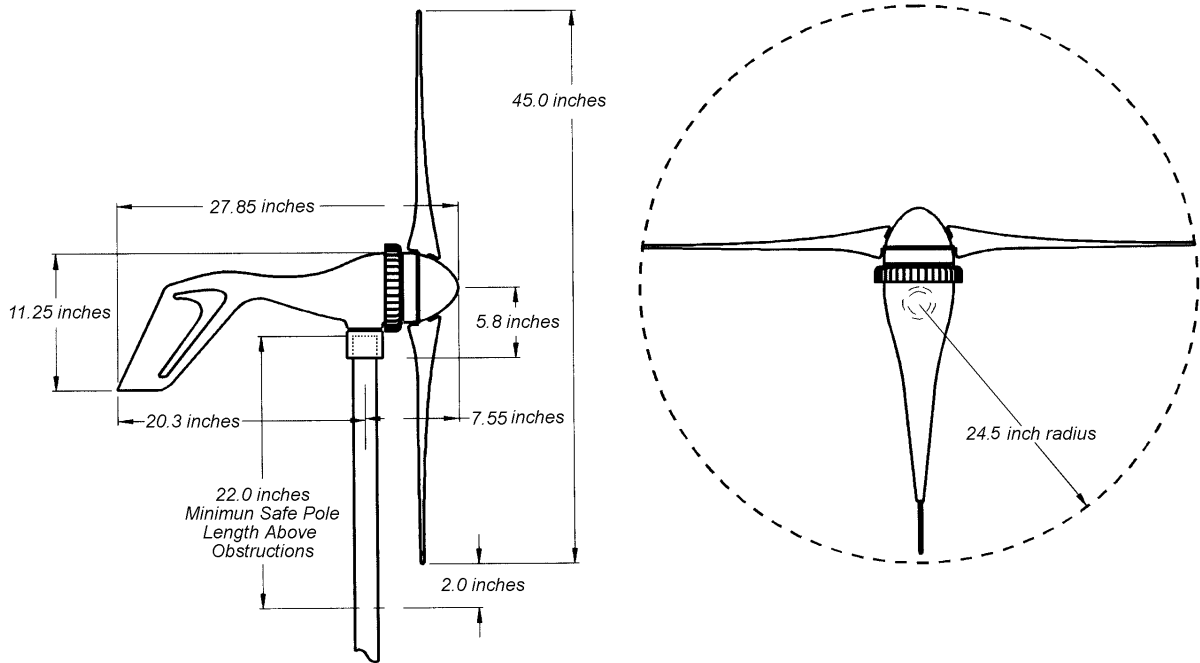

### 7.3 Exploded View of AIR Industrial

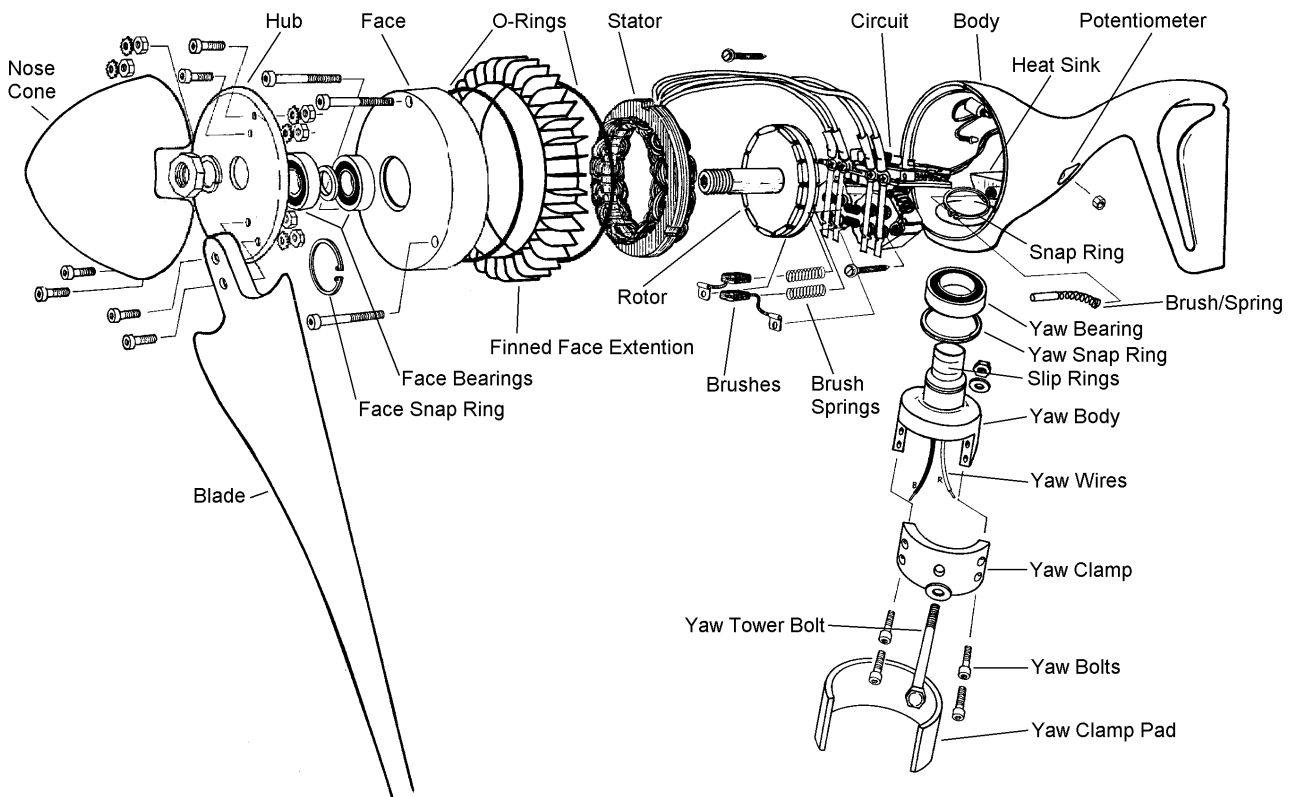

## 8. MAINTENANCE

Although your *AIR Industrial* has been designed to run for long periods without requiring any maintenance, reliability and performance will be enhanced if you periodically inspect your system. Before performing any inspection, be sure to shut down the turbine.

**CAUTION:** NEVER APPROACH THE TURBINE DURING OPERATION.

**CAUTION:** THE ROTOR BLADES ARE SHARP. PLEASE HANDLE WITH CARE.

During periodic inspection you should:

- Check blades for chips or nicks. Replace blades if necessary. **Do not operate the turbine with chipped or unbalanced blades. This can cause severe wear, damage, and possible failure. Do not install individual blades. The blades are balanced as sets.**
- Check all blade and hub bolts.
- Make sure the yaw bolts securing your *AIR Industrial* are tight.
- Inspect the tower.
- Dirt or debris build-up on the blades and body may cause a decrease in performance of the turbine and or long-term damage that is not covered by the warranty. Wash off any build-up with clean soap and water.
- Salt build-up may cause a decrease in performance of the turbine and long-term damage that is not covered by the warranty. Occasionally wash off any build-up with clean soap and water.
- Check all electrical connections to make sure they are tight and free from corrosion.
- As with all charging systems, check your battery water levels and add distilled water if necessary.
- Check the nose cone.

## 9. SYSTEM REQUIREMENTS AND CONSIDERATIONS

### 9.1 Batteries

The following is a brief description of three common batteries. There are many grades, sizes, voltages, and chemistries available. Battery life can vary from less than one year to more than ten years. **It is important to consult your dealer for the most up-to-date information and for help in selecting the appropriate battery.**

**NOTE:** Never use “automotive batteries” or any non deep-cycle battery.

**NOTE:** Refer to battery manufacture for specific recommendations regarding installation, maintenance, charging and operation.

**Lead Acid**, Wet Lead Acid or flooded lead-acid batteries are the most commonly used batteries to store electrical power. These are available in vented types (most common), where water can be added, and also in sealed types, where water cannot be added.

**GEL Cell** or sealed batteries are frequently selected in applications where batteries cannot be vented or cannot be mounted in an upright position. Gel cells are cleaner in the sense they do not vent the condensed gasses like lead acid batteries. However, gel cells are more sensitive to charge voltage since they can not vent except in emergencies (which may cause irreversible damage). Therefore, gel cells must be regulated properly. If using gel cells, follow the manufacturers’ recommended regulator set points. Gel cell batteries may require an external battery temperature compensated regulator. Consult your manufacturer for specific recommendations.

**Nickel Cadmium or Nickel Iron** batteries are generally used in extreme conditions. These batteries will perform at temperatures less than -40° C (-40° F). They are capable of delivering higher current and cycle deeper and more often than lead acid and gel batteries. Nickel iron batteries can have a 20+ year life. Nickel iron is one of the most environmentally friendly batteries; however, nickel cadmium batteries contain heavy metals. The disadvantages of this type of battery are its high cost and its low-efficiency charge. Consult your manufacturer for specific recommendations.

### 9.2 Regulator Options

The internal electronics protect you and your batteries from excess voltage from the **AIR Industrial**; they control the turbine rotor RPM, and serve as a flexible battery charge regulator. The internal regulator senses the voltage from the battery and determines whether or not to continue charging. The closer the battery voltage is to the regulation set point, the more frequently the regulator checks the battery voltage. Once the battery voltage matches the regulation set point the regulator will “stop” the turbine from charging. (*In high winds there will still be a trickle charge.*)

It is important to keep in mind that battery charge efficiency varies in extreme temperatures. If these extreme conditions exist, an external regulator with a temperature compensation sensor should be used to optimize the charge rate. There are several regulators available that adjust the charge rate based on ambient battery temperature.

There are some conditions in which the **AIR Industrial's** internal regulator is not appropriate as the primary regulator. These conditions include:

- systems where battery temperature varies widely
- if batteries are small or sensitive
- if multiple turbines are used with a bus system
- systems with a very small battery bank, contact Southwest Windpower for "low power" wiring information

The **AIR Industrial** offers you three basic regulation choices:

1. Use the **AIR Industrial** at its factory settings.

**AIR Industrial Adjustable Voltage Range**

**12v** 13.8v 17.8v *preset to 14.1v*

**24v** 27.6v 35.6v *preset to 28.2v*

**36v** 41.4v 53.4v *preset to 42.3v*

**48v** 55.2v 71.2v *preset to 56.4v*

2. Adjust the regulator to your systems requirements. The voltage adjustment is external as indicated in **Figure 7 on page 16**. This allows you to adjust **AIR Industrial's** internal regulator to the exact voltage specified by the battery manufacturer. Refer to **Section 4.4 on page 22** for regulator adjustment instructions.

**NOTE:** Refer to the battery manufacturers' specifications for exact regulation set points.

3. Use an external regulator. A standard diversion load regulator like that used with solar panels will work fine as long as the regulation rating is greater than 300 Watts. If you choose to use this option you must turn "off" the internal regulator by gently turning the adjustment screw all the way clockwise.

*Types Of Regulators*

The three types of regulators available are shunt, Pulse Width Modulated (*PWM*) and diversion style.

A diversion style regulator allows the batteries to become charged and "diverts" the excess power to a resistive load. This allows you to maintain a load on the turbine even when the battery is full. The most common use for this excess power is heating water.

## 10. SITING

In any location, the closer you get to the surface of the earth, the slower the wind speed. This is a result of the friction of the earth and obstacles on the surface. Turbulence caused by obstacles will reduce the efficiency of any wind turbine. Therefore, locate the turbine in a site that has the “cleanest” free-flowing wind possible.

Power in the wind is the cubic function of the wind speed. Small changes in wind speed can have dramatic changes in output. Each time the wind speed doubles, the **AIR Industrial** is capable of increasing power by eight times! Even slight changes have dramatic effects. For example, an increase from 6 m/s to 7 m/s is only 17% greater in wind speed; however, the energy gain is 60%!

For land applications, the turbine should be mounted on a tower a minimum of 15' (5 meters) above any surrounding objects within a 500' (150 m) radius. If this is not possible, place the turbine as high as you can. If this is a roof top installation, no objects can be around the structure that may block the wind.

**CAUTION:** DO NOT INSTALL THE TURBINE WHERE THE PATH OF THE BLADES CAN BE REACHED.

**CAUTION:** DO NOT APPROACH THE TURBINE FOR ANY REASON UNLESS ROTOR BLADES ARE STOPPED.

You can get a fairly good estimate of the local average wind speed by looking at the local vegetation. Look at the following drawings for information on estimating your local average wind speed.

The first figure shows how tower height can dramatically affect output.

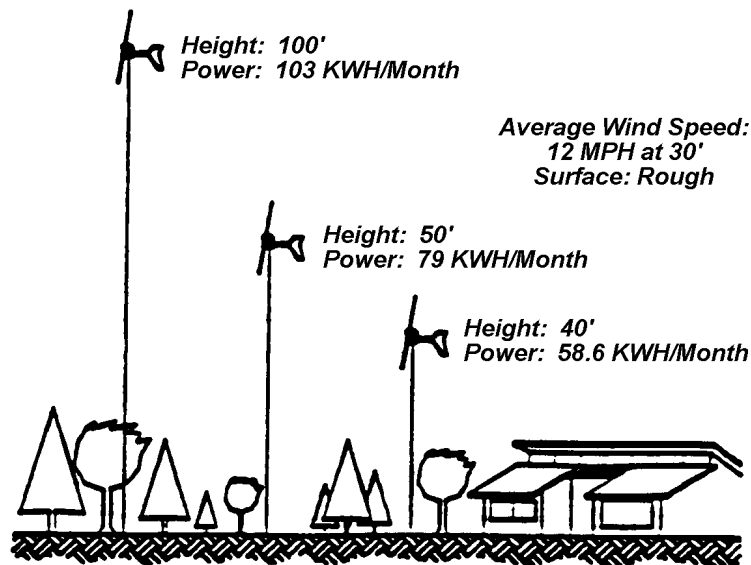
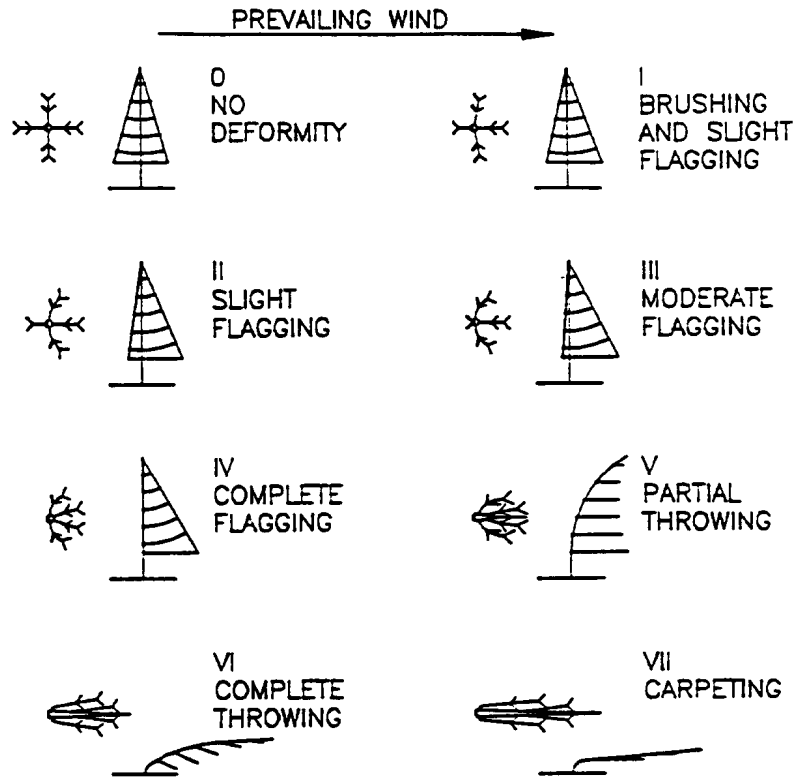

Figure 8



WIND SPEED RATING SCALE BASED ON THE SHAPE OF THE CROWN AND DEGREE TWIGS, BRANCHES AND TRUNK ARE BENT (GRIGGS-PUTNAM INDEX: WADE AND BAKER, 1977)

MEAN ANNUAL WIND SPEED VERSUS THE GRIGGS-PUTNAM INDEX

GRIGGS-PUTNAM INDEX	0	I	II	III	IV	V	VI
PROBABLE MEAN ANNUAL WIND SPEED RANGE (mph)	0-7	7-9	9-11	11-13	13-16	15-18	16-21
WIND SPEED RANGE (m/s)	0-3	3-4	4-5	5-6	6-8	7-9	8-10

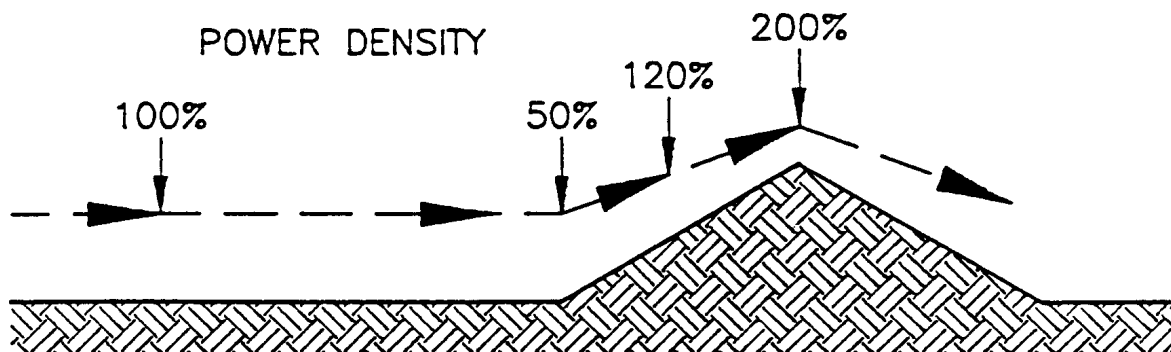

Figure 9

## 11. TOWERS

You should consider a couple of aspects when choosing the correct tower for your turbine, site and budget:

- site: trees, hills, buildings
- tower budget
- space for tower; guyed, freestanding, rooftop
- number of turbines to be installed
- ease of use

It is important to mount the turbine in the best winds, yet the cost and ease of installation are also important factors. The higher the tower, the greater the output. However, the taller tower, the greater tower cost and effort. If purchasing a taller tower will provide with significantly more power, the additional cost may it may be offset.

The **AIR Industrial** has been designed to be mounted on 1 1/2 ", SCH 40 (*outside diameter 1.875 inch, 48mm*) steel or aluminum pipe. If you have a tower with a larger size pipe that is reduced just before the turbine for mounting, make sure that the 1 1/2 ", SCH 40 pipe stub is at least 26" (66 cm) long. Larger pipes will reduce the blade tip clearance and cause premature failure of the blades. Refer to Figure 6 on page 15.

**CAUTION:** PROPER ENGINEERING, SAFETY CONSIDERATIONS AND LOCAL CODES SHOULD BE ADDRESSED BEFORE ATTEMPTING **ANY** INSTALLATION.

**NOTE:** The yaw wires can support loads up to a total of 150 lbs. (68 kg) in wire weight. For higher wire weights, you must install a strain relief to minimize the stress put on the hanging wires.

**NOTE:** No more than 8 feet (2.5 m) of pipe should extend from the last support.

**NOTE:** Towers should be capable of withstanding 150 lb. (68 kg) of load in the horizontal direction at the turbine.

### 11.1 Guyed Towers

Guyed and freestanding towers are used mostly to install wind generators. These towers are available in all shapes, sizes and costs. As with all towers, you must first evaluate your site to determine the appropriate tower height, available space and reasonable cost.

### 11.2 Roof Top

One of the revolutionary features of the **AIR Industrial** is its modular design. This allows for the use of multiple turbines to achieve the desired power production. Roof top mounts offer relatively easy multiple turbine installations if the site allows.

Basic aerodynamics show that as wind moves over or around objects, the wind compresses and accelerates. It is possible to use a building rooftop to increase the turbine's output using this accelerated wind. The amount of acceleration will vary greatly with house design, wind direction, local obstructions and terrain.

There are considerable differences in acceleration due to the angle and height of a structure and nearby obstructions. However, a location of 5 feet (1.5 m) to 8 feet (2.5 m) above the structure produces substantial acceleration in average situations and is tolerant of different wind directions.

For ideal sites where the prevailing wind is perpendicular to the roof-ridge line, the **AIR Industrial** may be mounted fairly close together 9 feet (2.75 m), center to center. However, if your wind primarily comes from a direction along the roof-ridge line, then the turbines must be spaced to minimize interference 12 to 15 feet (3.6 to 4.5 m) and mounted as high as possible (8 feet (2.5 m) maximum unsupported pipe). Less acceleration occurs when the wind is parallel to the roof line.

When the prevailing wind is perpendicular to the roof edge, mount your first **AIR Industrial** in the center of the roof ridge and add turbines to either side along the roof ridge. Where the prevailing wind parallels the roof-ridge line, mount your first **AIR Industrial** on the end of the structure closest to the wind, and about 3 feet (1 meter) from the edge.

Although a rooftop can be used to accelerate the wind flowing past a house, a tower that is much taller will experience higher winds and greater output. The advantages of rooftop mounting are ease of mounting, low tower cost and multiple installations. The disadvantages are lower wind speeds, increased turbulence and noise,

**NOTE:** Uniform building code requires that a structure must support the wind load it creates by the area presented to the wind. The structural load applied by the wind increases with wind speed. Any additional loads that increase area during serious storms must be compensated for.

**NOTE:** Any wind generator can create vibration. If available it is always better to mount a wind generator on an unoccupied building.

**CAUTION:** DO NOT INSTALL THE TURBINE WHERE THE PATH OF THE BLADES CAN BE REACHED DURING NORMAL OPERATION,

Southwest Windpower offers tower kits for boats. The kits include three rubber isolation mounts. These mounts reduce transmitted vibration (*inherent with any wind turbine*), and allow for simple installation for the turbine. [Refer to Section 13. on page 38](#) for tower information and other accessories. Check with your dealer for availability of these kits.

## 12. FREQUENTLY ASKED QUESTIONS

These frequently asked questions are in no particular order. Please take the time to read through all the questions, you will have a better understanding of the features and operation of your **AIR Industrial**.

### Can I disconnect my **AIR Industrial** without damaging it?

You can disconnect your **AIR Industrial** turbine without causing any damage. The **AIR Industrial's** sophisticated electronics control the voltage. The turbine will become louder when it is disconnected especially in higher wind speeds. (*Not recommended for extended periods.*)

### Is it possible to short my **AIR Industrial** turbine?

Yes, you can short your **AIR Industrial** turbine without causing any damage; however, **be sure you do not short your batteries!** Shorting batteries can cause serious damage. First disconnect the turbine from the battery and then connect the *turbine* positive wire to the *turbine* negative wire. Doing this will “stop” the turbine from spinning. Refer to the “Four Spinning Conditions” of the **AIR Industrial** in [Section 4.1.4. on page 19](#) Also refer to the section on Stop Switches in [Section 3.1.5 on page 11](#). The stop switch can be used to stop the turbine by disconnecting the battery and shorting the turbine wires.

### Can the turbine be hooked up backwards to the battery without causing any damage?

NO! If you hook the turbine up backwards to the battery you will damage the turbine and void your warranty. Make sure to hook the positive (red) wire to the positive post on the battery, and hook the negative (black) wire to the negative battery post.

### Where can I locate tubing to make a tower?

The **AIR Industrial** uses 1 1/2” schedule 40 steel or aluminum pipe. (*Actual outside diameter (O.D.) of the pipe is 1.875 inches, 48 mm*) Steel pipe is available at any hardware or plumbing store. Aluminum pipe can be found at most electrical hardware stores. Ask for electrical aluminum conduit.

### Where can I locate a stop switch?

If you want to install a stop switch it must be a 50 amp DC Single-Pole Double-Throw toggle switch. This can be purchased from most automotive electrical repair Industrial shops, your dealer, or from Southwest Windpower.

### What type of regulator do I need to use?

You may use **AIR Industrial's** internal regulator or any other type of “Diversion Load” regulator that is intended for use with solar panels. See [Sections 9.2 on page 29](#) for more details.

### How do I adjust the regulator?

Refer to [Section 4.4 on page 22](#).

### How does the **AIR Industrial** control power and RPM in high winds?

The **AIR Industrial** uses a unique rotor blade made of carbon fiber-reinforced thermoplastic. As the wind reaches approximately 48 mph (21.5 m/s), aerodynamic

forces cause the blades to twist and the rotor to stall. This is a passive function that slows the rotor to protect it.

**Why do I hear an unusual noise when wind speed nears 50 mph?**

This noise occurs when the aeroelastic twisting blades reach a deep stall. The noise is normal and protects your **AIR Industrial** turbine in high winds. If this high wind noise is undesirable, stop the turbine by shorting the *turbine* wires or through the use of a stop switch.

**Why is the casting made of aluminum; why not a cheaper or lighter material?**

The aluminum body provides a functional structure and also acts as a heat sink that cools the alternator and electronics at high power levels. The weight of the aluminum also adds stability in high winds.

**Why is there a cut-out in the tail?**

***Balance***

The cut-out helps to balance the **AIR Industrial** on its turning axis to better track the wind. Since the turbine only weighs 14 lbs (6.2 kg) and is properly balanced, more power can be extracted from the wind no matter how slight or directionally unstable.

Also, if mounted on a vessel or floating buoy, the **AIR Industrial** will keep pointed into the wind even when the pole is heeled over.

***Wind Tracking***

The cut-out also helps to create more edge surface area which provides more directional thrust for turning the turbine into the wind.

**Will the LED burn out?**

The LED is a solid state device with a much longer life than conventional bulbs or fluorescent lights. It should last a lifetime. (*Your unit will work fine even if the LED fails.*)

**How long will the bearings or other wearing parts last?**

According to engineering calculations, the bearings should have a 10 year life in 12 mph (6 m/s) average wind speed sites. Bearing life will vary from one application to another; however, you should expect at least a five year performance in adverse conditions and 10 years in normal conditions.

The copper brushes should last a lifetime. The yaw shaft has been tested to over 100,000 revolutions with no visible wear on the brushes or slip rings.

**What is the maximum wind speed the **AIR Industrial** will survive, and do I need to take it down in a storm?**

**NEVER** approach the **AIR Industrial** or any turbine in strong wind conditions. The **AIR Industrial** is designed to run without attention in storm conditions. If you wish to shutdown the turbine you can do so remotely as described in Section 3.1.5. The **AIR Industrial** is rated to 120 mph (60 m/s).

**How do I know the turbine is charging?**

For a precise indication of charge current you will need to install an amp meter in your system.

**Why is the *AIR Industrial* turbine so powerful for its size, weight, and cost?**

Almost every part of the turbine has been developed from “the ground up” using 3-D computer models to help analyze every element of the design. As a result, this state-of-the-art turbine features the following:

- The *AIR Industrial* is the only turbine that uses a permanent magnet (PM) alternator that matches the cubic power of the wind. All other PM alternators are linear in their output and either stall or unload the rotor blades making them very inefficient.
- The *AIR Industrial* uses 12 *Neodymium Iron Boron* magnets which are the strongest magnets available in the world.
- This is the first wind turbine to use blades with advanced airfoils made of injection-molded carbon-composite materials that meet the strength-to-weight ratio requirements of this computer assisted design.
- The blades have aeroelastic twist that provides durability and simplicity.
- The electronic circuit/alternator allows the turbine to self-regulate.
- Most important, has been the conviction and passion of our team. While overcoming seemingly insurmountable obstacles, together we maintain our desire to help change the world by providing quality renewable energy innovations.

### 13. ACCESSORIES

Southwest Windpower offers a line of accessories for your turbine. Some of these accessories are difficult to find due to the high DC outputs. We offer them as a convenience to you. They may be available at an automotive parts store. Otherwise you can purchase them from your dealer/distributor or directly from Southwest Windpower.

#### Stop Switch

The 50 amp DC Stop Switch can be used to “stop” the turbine for service or any other reason. Refer to the Stop Switch wiring diagram in [Section 3.1.5 on page 11](#).

#### Amp Meter

The Amp Meter allows you to monitor the output of your turbine. Place it in between your turbine and the battery on the positive lead. It will give you instantaneous readings of output in amps.

#### Circuit Breaker

A Circuit Breaker is required with any electrical installation. In the event of a system or turbine failure the circuit breaker disconnects the battery and prevents the possibility of further damage. Make sure to purchase the proper size DC breaker.

12 volt = 50 amp

24 volt = 30 amp

#### Marine Tower kits

The marine tower kit is available for mounting the *AIR Industrial* on boats. The Stay Base and the Tilting Mast Base incorporate three rubber isolation mounts to reduce transmitted vibration. Contact your dealer for pricing and information.

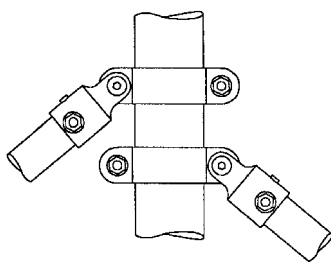

**A. Saddle Clamps**

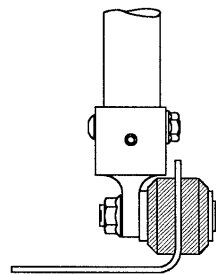

**B. Stay Base**

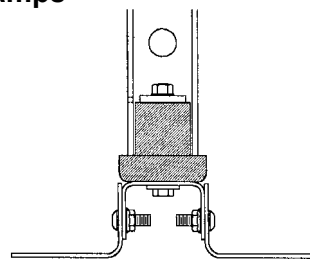

**C. Tilting Mast Base**

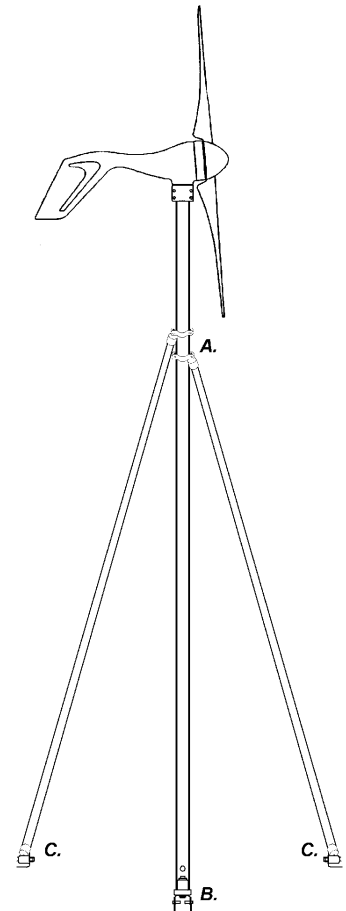

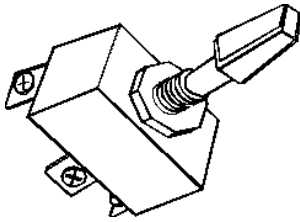

**Stop Switch**

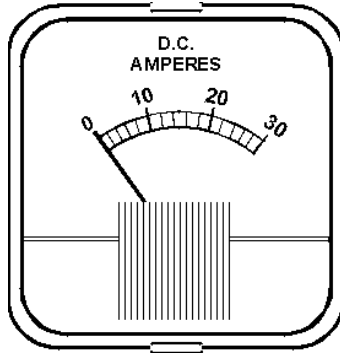

**Amp Meter**

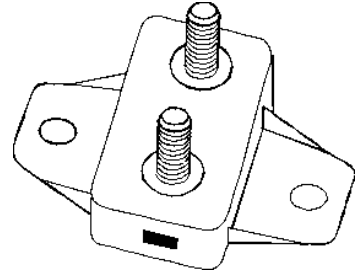

**Circuit Breaker**

**Guyed tower Kits**

We offer 25' (7.5 m) and 47' (14 m) guyed towers. These towers are relatively low cost and easy to install. Contact your dealer for pricing and product information.

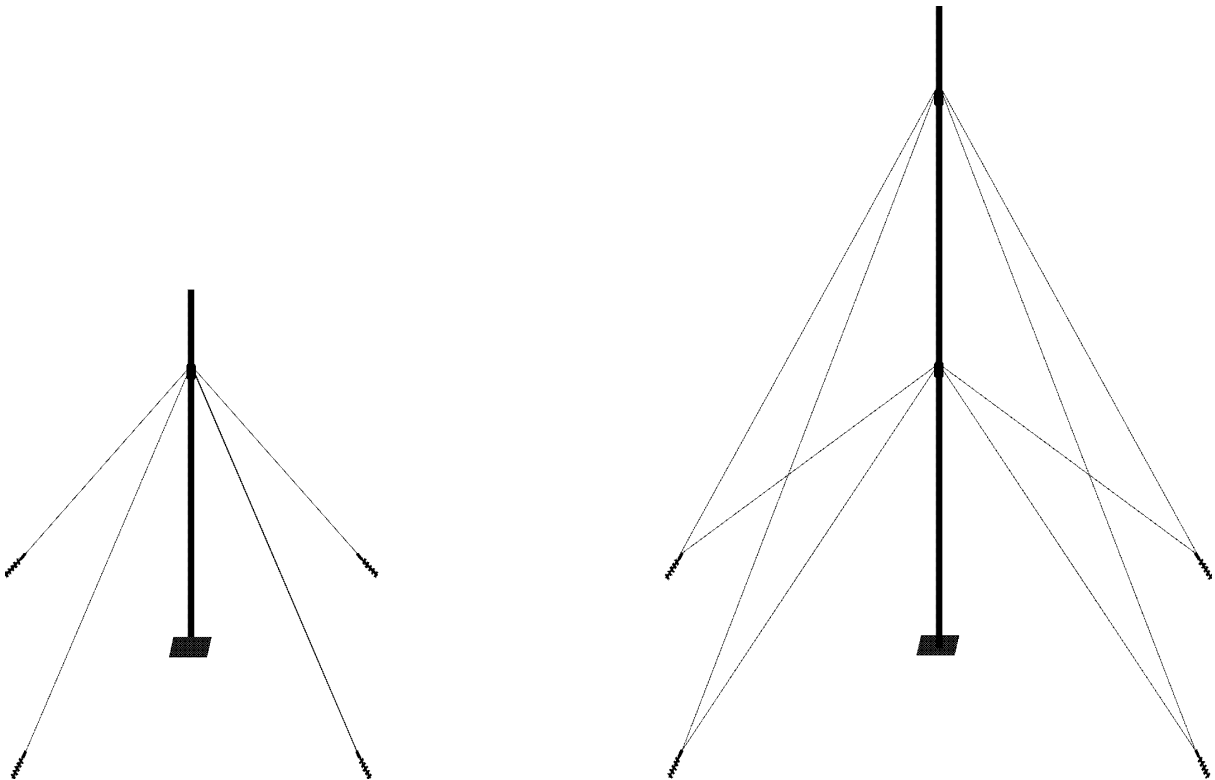

## **14. REFERENCES**

### **Wind Energy**

#### **The Wind Power Book**

J. Park Hackleman  
Cheshire Books, 1981  
Palo Alto, CA

#### **The Home Built, Wind Generated Electricity Handbook**

M. Hackleman  
Peace Press, 1975  
Culver, CA

#### **Wind Energy, How To Use It**

P. Gipe  
Stackpole Books, 1983

#### **Wind Power For The Home Owner**

D. Marier  
Rodale Press  
Emmaus, PA

### **Batteries**

#### **The Battery Book**

R. Perez  
Home Power Magazine  
P.O. Box 520  
Ashland, OR 97520  
(970) 475-0830

### **Marine Applications**

#### **Boat Owners Mechanical and Electrical Manual**

Nigel Calder  
International Marine Publications, 1996  
(800) 722-4726

#### **Boat Owners Illustrated Handbook of Wiring**

Charlie Wing  
International Marine Publications  
(800) 722-4726

#### **ABYC (*American Boat and Yacht Council*)**

3069 Solomon's Island Road  
Edgewater, MD 21037  
(410) 956-1050

### **Siting**

**A Siting Handbook for Small Wind Energy Conversion Systems**

H.L. Wegley, J.V. Ramsdell, NM Orgill, and R.L. Drake  
National Technical Information Service, 1980  
(703) 487-4600

**Tower Construction**

**Uniform Building Code - Section 2311 - Wind Design**

UBC International Conference of Building Officials, May 1985

**Lightning Protection**

**Lightning Protection**

R.H. Golde  
Chemical Publishing Co., Inc., 1975  
New York

**Lightning Code Section 78**

National Fire Codes, Volume 7, 1978  
National Fire Protection Association  
(Available at your Library)

**Resources**

National Technical Information Service  
United States Department of Commerce  
5285 Port Royal Rd.  
Springfield, VA 22161  
(703) 487-4600

The American Wind Energy Association (AWEA)  
122 C Street NW, Fourth Floor  
Washington, D.C. 20001  
(202) 408-8988

NRG Systems (Monitoring Equipment Manufacturer)  
110 Commerce Street  
Hinesburg, VT 05461  
(802) 482-2255

**National Electrical Codes**

National Electrical Code (NEC)  
National Fire Protection Association