

PS200 HR

Solar-operated Submersible Pump System, 4" Helical Rotor (HR) Pump Unit

Characteristics

- lift up to 50 m
- flow rate up to 2.7 m³/h
- simple installation
- maintenance-free
- high reliability and life expectancy
- cost-efficient pumping

Applications

- drinking water supply
- livestock watering
- pond management
- irrigation
- etc.

Components

Controller PS200

- controlling of the pump system and monitoring of the operating states
- mounted at surface (no electronic parts submerged)
- two control inputs for well probe (dry running protection), float or pressure switches, remote control etc.
- automatic reset 20 minutes after well probe turns pump off
- protected against reverse polarity, overload and high temperature
- speed control, max. pump speed adjustable to reduce flow rate to c. 30 %
- solar operation: integrated MPPT (Maximum Power Point Tracking)
- battery operation: low voltage disconnect and restart after battery has recovered
- max. efficiency 92 % (motor + controller)
- enclosure: IP 54 (sealed, weatherproof)

Motor ECDRIVE 600HR

- brushless DC motor
- no electronics inside motor
- water filled
- IP68, pressure balanced, unlimited submersion
- dynamic slide bearings, material: carbon/ceramic
- wetted material: stainless steel (AISI 316), POM, rubber, cable drinking water approved

Pump End (PE)

- helical rotor pump (positive displacement pump)
- two main parts only: stator and rotor, field serviceable
- stator: geometry made of abrasion resistant rubber
- rotor: stainless steel, hard chrome plated, abrasion resistant
- more resistant to damage by sand than other pump types
- high life expectancy
- non-return valve
- dry running protection (optional)
- material: stainless steel (AISI 316), rubber
- self-cleaning

Performance

PS200	HR-04	HR-07	HR-14
article #	1007-X	1009-X	1008-X
lift [m]	0–50	0–30	0–20
max. flow rate [m ³ /h]	0.8	1.2	2.7
max. efficiency [%]	60	61	62
solar operation	nominal voltage 24–48VDC, open circuit voltage max. 100VDC		
solar generator [Wp]	80–300	80–300	80–300
battery operation	nominal voltage 24–48VDC		



System Sizing Table: Battery Operation

PS200 HR, 24V, Battery Operation

vertical lift		pump type	peak flow rate		power [W]	wire size [mm ²]
[m]	[ft]		[l/min]	[US Gal/min]		
5	16	HR-04	5.5	1.5	24	2.5
		HR-07	7.5	2.0	37	
		HR-14	17.5	4.6	40	
10	33	HR-04	5.2	1.4	29	2.5
		HR-07	7.5	2.0	42	
		HR-14	16.6	4.4	55	
15	50	HR-04	4.8	1.3	34	2.5
		HR-07	7.0	1.8	50	
		HR-14	15.2	4.0	74	
20	65	HR-04	4.5	1.2	38	2.5
		HR-07	6.5	1.7	60	
		HR-14	12.5	3.3	91	
30	100	HR-04	4.2	1.1	48	4.0
40	130	HR-04	3.8	1.0	58	4.0
50	165	HR-04	3.3	0.9	65	4.0

PS200 HR, 48V, Battery Operation

vertical lift		pump type	peak flow rate		power [W]	wire size [mm ²]
[m]	[ft]		[l/min]	[US Gal/min]		
5	16	HR-04	11.0	2.9	55	2.5
		HR-07	17.0	4.5	90	
		HR-14	38.4	10.1	130	
10	33	HR-04	10.3	2.7	70	2.5
		HR-07	16.5	4.4	100	
		HR-14	36.1	9.5	165	
15	50	HR-04	10.1	2.7	80	2.5
		HR-07	15.8	4.2	115	
		HR-14	35.0	9.2	195	
20	65	HR-04	9.8	2.6	90	2.5
		HR-07	15.5	4.1	135	
		HR-14	33.0	8.8	165	
30	100	HR-04	9.3	2.5	105	4.0
		HR-07	14.2	3.8	160	
40	130	HR-04	8.7	2.3	125	4.0
		HR-07	13.5	3.6	190	
50	165	HR-04	7.8	2.1	140	4.0

For Battery and Solar Direct Systems

Lift Limits

These systems are selected for optimum performance. To allow unexpected drawdown, each system can handle an additional 15% lift.

Higher Lift? Higher Flow Rate?

Choose PS600/1200 for higher lift, higher flow rate applications and lower cable cost.

Wire Sizes

Cable Layout is calculated to stay within 4% power loss.

Variations of Length

Longer: for each 50% increase, the next larger wire size is required

Shorter: for each 33% decrease, the next smaller wire size is required

Array To Controller: if shorter than 6m/20ft: 4mm² / #10 min.

Controller To Low-Water Probe: 1mm²/#18 min. 2-conductor

For Solar Direct Systems

System Voltage

24-48V nominal, e.g. 2 to 4 standard 12V modules wired in series, Voc 100V max.

How Daily Water Volume Is Calculated

Daily volume is calculated by integrating real flow versus realistic solar (PV) output through the day.

The solar array is fixed at tilt angle = latitude of the location.

irradiation:

kWh/m²/day = peak sun hours/day

Flow rates may vary +/- 10%

System Sizing Table: Solar-direct operation

PS200 HR, 24V nominal voltage
2× 12V standard modules in series

irradiation 4.0 kWh/m²/day, tilted surface

vertical lift		pump type	peak flow rate	flow rate for PV array power peak			wire size
[m]	[ft]			[l/min]	80Wp	120Wp	
5	16	HR-04	7.2	2.2	2.5	2.8	2.5
		HR-07	13.0	2.0	3.5	4.7	
10	33	HR-04	6.5	2.0	2.3	2.6	2.5
		HR-07	13.0	1.7	3.0	4.2	
15	50	HR-04	6.0	1.8	2.0	2.4	2.5
		HR-07	12.0	1.5	2.8	3.9	
20	65	HR-04	5.8	1.4	1.6	2.2	2.5
		HR-07	12.0	1.1	2.5	3.7	
25	82	HR-04	5.7	1.1	1.5	2.1	2.5
30	100	HR-04	5.5	0.8	1.2	2.0	2.5
40	130	HR-04	5.1	-	1.0	1.8	4.0
50	165	HR-04	5.1	see 36-48V table			4.0

irradiation 6.0 kWh/m²/day, tilted surface

vertical lift		pump type	peak flow rate	flow rate for PV array power peak			wire size
[m]	[ft]			[l/min]	80Wp	120Wp	
5	16	HR-04	7.2	3.5	3.8	4.0	2.5
		HR-07	13.0	4.0	6.0	7.0	
10	33	HR-04	6.5	3.3	3.6	4.0	2.5
		HR-07	13.0	3.9	5.2	5.4	
15	50	HR-04	6.0	2.9	3.5	4.0	2.5
		HR-07	12.0	3.5	5.0	5.2	
20	65	HR-04	5.8	2.5	3.3	3.9	2.5
		HR-07	12.0	2.4	3.8	4.9	
25	82	HR-04	5.7	2.2	3.0	3.5	2.5
30	100	HR-04	5.5	1.9	2.8	3.1	2.5
40	130	HR-04	5.1	-	2.0	2.5	4.0
50	165	HR-04	5.1	see 36-48V table			4.0

PS200 HR, 36-48V nominal voltage
3–4× 12V standard modules in series

irradiation 4.0 kWh/m²/day, tilted surface

vertical lift		pump type	peak flow rate	flow rate for PV array power peak			wire size
[m]	[ft]			[l/min]	150Wp	200Wp	
5	16	HR-04	12.0	4.8	5.4	6.4	2.5
		HR-07	19.5	4.7	7.0	8.5	
10	33	HR-04	11.8	4.5	5.0	6.0	2.5
		HR-07	19.0	4.2	6.0	7.5	
15	50	HR-04	11.5	4.0	4.6	5.7	2.5
		HR-07	18.5	3.9	6.0	7.4	
20	65	HR-04	11.5	3.5	4.2	5.4	2.5
		HR-07	18.0	3.3	5.5	7.0	
25	82	HR-04	11.3	2.6	3.6	5.1	2.5
		HR-07	17.5	-	2.5	4.0	
30	100	HR-04	11.0	2.0	3.0	4.8	2.5
40	130	HR-04	11.0	1.7	2.4	3.5	4.0
50	165	HR-04	10.5	1.3	2.0	3.0	4.0

irradiation 6.0 kWh/m²/day, tilted surface

vertical lift		pump type	peak flow rate	flow rate for PV array power peak			wire size
[m]	[ft]			[l/min]	150Wp	200Wp	
5	16	HR-04	12.0	6.3	6.6	7.3	2.5
		HR-07	19.5	8.5	9.5	10.5	
		HR-14	36.0	11.0	15.0	18.0	
10	33	HR-04	11.8	6.0	6.5	7.0	2.5
		HR-07	19.0	8.0	9.0	10.0	
		HR-14	34.0	9.0	13.0	16.0	
15	50	HR-04	11.5	5.5	6.0	6.8	2.5
		HR-07	18.5	7.0	8.3	9.5	
		HR-14	33.0	8.0	11.0	14.0	
20	65	HR-04	11.5	5.5	6.2	6.6	2.5
		HR-07	18.0	6.0	7.5	9.0	
		HR-04	11.3	5.0	5.6	6.2	
25	82	HR-07	17.5	5.0	6.5	8.0	2.5
		HR-04	11.0	4.3	4.9	5.8	
30	100	HR-04	11.0	3.0	4.0	5.0	4.0
40	130	HR-04	11.0	3.0	4.0	5.0	4.0
50	165	HR-04	10.5	2.0	3.0	4.2	4.0

Conversion for Wire Sizes

AWG	mm ²
# 18	1
# 12	4
# 10	6
# 8	10
# 6	16

Conversion for Flow Rates

1 m ³	264 US Gal.
1 m ³	220 Imp. Gal.
1 l/min	0.264 US Gal/min
1 l/min	0.220 Imp. Gal/min

Conversion for Lift/Length

1 m	3.3 ft
-----	--------

Table shows nearest larger metric cross section.

Dimensions and Weights

	dimensions					shipping dimensions			
	L	A	B	D	S	packaging	shipping volume	net weight	gross weight
	[mm]	[mm]	[mm]	[mm]	[mm]	[mm]	[m³]	[kg]	[kg]
Pump Unit (PU) (motor + pump end)									
HR-04	780	595	185	96	G 1 ¼ in	850×160×150	0.0204	11.2	12.0
HR-07, HR-14	771	586	185	96	G 1 ¼ in	850×160×150	0.0204	11.5	12.3
Controller									
PS200						320×240×160	0.0123	1.2	1.8

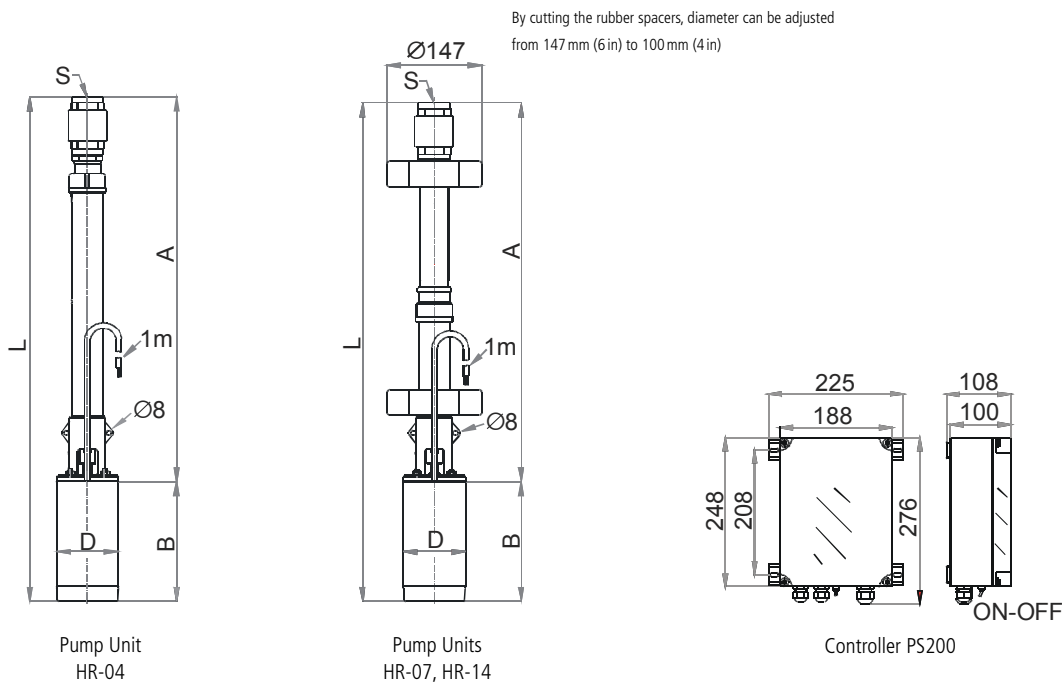

Sand and Silt Tolerance

The pump (HR) has a higher resistance to wear from sand, clay etc. than any other pump type. In properly constructed wells the amount of solid particles is within the tolerance of the pump.

A concentration of particles higher than 2 % (by volume) may cause blockage in the pump or the drop pipe, especially at low flow rates.

Do not use the pump to clean out a dirty well.

Pump Cable and Splice

Standard submersible cable, 3-wire + ground (total four wires). Connection to the pump is made using industry-standard splicing methods.

Drop Pipe

G 1 ¼ in (optional: 1 in NPT) pump outlet. If water is dirty consider a smaller sized drop pipe to increase the flow velocity. This helps to exhaust solid particles and prevent accumulation in the pipe. When considering reduced pipe size, consult a pipe sizing (friction loss) chart. Pipe can be of any standard material, rigid or flexible. A torque arrestor is not required.

Temperature Limits

Pump end, motor: water temperature up to +40°C (+104°F)

Specify temperature range on order.

Controller: ambient temperature -30°C to +55°C (-22°F to +131°F)

Warranty

Two years manufacturer's warranty against defects in material and workmanship