

## SolarMount-I™ Roof Mount Technical Datasheet

Pub 101109-1td V1.1 November 2010

SolarMount-I Module Connection Hardware

- Slider and Mid Clamp..... 1
- Slider and End Clamp..... 2
- SolarMount-I Series Accessory Mount..... 2

SolarMount-I Beam Connection Hardware

- 1- Flange Foot..... 3
- 2- Flange Foot..... 3
- Beam Splice..... 4

SolarMount-I Beam

- SolarMount-I Beams..... 5

SolarMount-I Engineering Reports

- SolarMount-I 1.0 Beams..... 6
- SolarMount-I 2.5 Beams..... 8

### SolarMount-I Module Connection Hardware

#### SolarMount-I Series Slider with Mid Clamp Part No. 02027C, 02028C, 02029C, 02030C

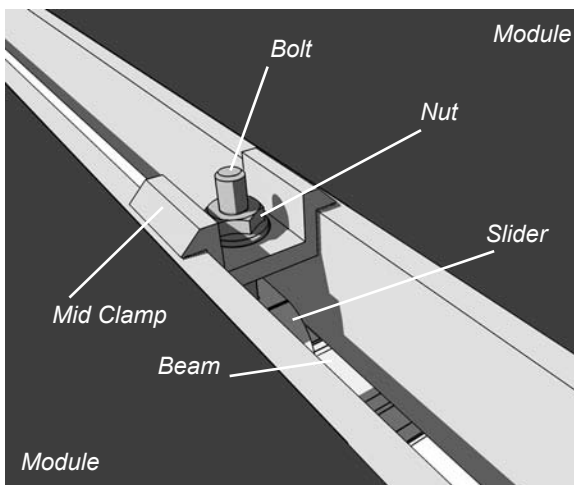

- **Slider and Mid Clamp Material:** One of the following mill finished extruded aluminum alloys: 6005-T5, 6105-T5, 6061-T6  
**Ultimate Tensile:** 38ksi, **Yield:** 35 ksi
- **Slider Weight:** 0.026 lbs (12g), **Mid Clamp Weight:** 0.050 lbs (23g)
- Allowable and design loads are valid when components are assembled with SolarMount-I Beams according to authorized UNIRAC documents
- Sliders are compatible with SolarMount-I Beams
- Assemble with one ¼-20 ASTM F593 bolt and one ¼-20 ASTM F594 serrated flange nut
- Use anti-seize and tighten to 10 ft-lbs of torque
- Resistance factors and safety factors are determined according to part 1 section 9 of the 2005 Aluminum Design Manual

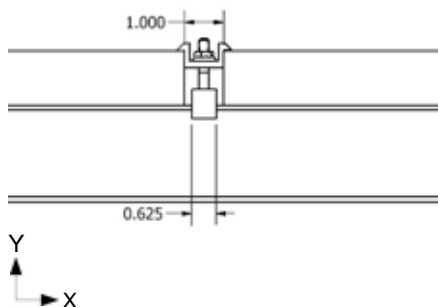

Dimensions specified in inches unless noted

Applied Load Direction	Average Ultimate lbs (N)	Allowable Load lbs (N)	Safety Factor, FS	Design Load lbs (N)	Resistance Factor, $\Phi$
Sliding, X±	1194 (5311)	490 (2180)	2.44	741 (3296)	0.620
Tension, Y+	1503 (6686)	677 (3011)	2.22	1024 (4555)	0.682
Transverse, Z±	2080 (9252)	915 (4070)	2.27	1383 (6152)	0.665

## SolarMount-I Module Connection Hardware

### SolarMount-I Slider with End Clamp Part No. 02001C through 02006C, 02009C, 02010C

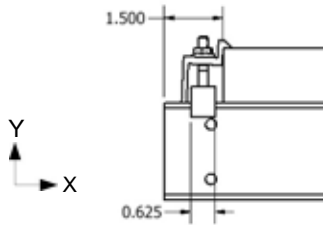
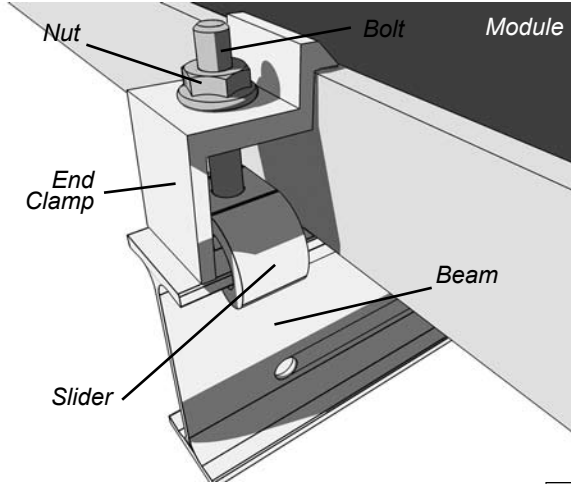

Dimensions specified in inches unless noted

- **Slider and End Clamp Material:** One of the following mill finished extruded aluminum alloys: 6005-T5, 6105-T5, 6061-T6  
**Ultimate Tensile:** 38 ksi, **Yield:** 35 ksi
- **Slider Weight:** 0.026 lbs (12g), end clamp weight varies based on height: ~0.058 lbs (26g)
- Allowable and design loads are valid when components are assembled with SolarMount-I 1.0 or 2.5 Beams according to authorized UNIRAC documents
- Sliders are compatible with SolarMount-I Beams
- Assemble with one ¼-20 ASTM F593 bolt and one ¼-20 ASTM F594 serrated flange nut
- Use anti-seize and tighten to 10 ft-lbs of torque
- Resistance factors and safety factors are determined according to part 1 section 9 of the 2005 Aluminum Design Manual
- Modules must be installed at least 1.5" from either end of a beam

Applied Load Direction	Average Ultimate lbs (N)	Allowable Load lbs (N)	Safety Factor, FS	Design Loads lbs (N)	Resistance Factor, Φ
Sliding, X±	283 (1259)	104 (463)	2.72	157 (698)	0.555
Tension, Y+	332 (1477)	88 (391)	3.77	133 (592)	0.401
Transverse, Z±	1367 (6081)	533 (2371)	2.56	806 (3585)	0.590

### SolarMount-I Accessory Mount Part No. 08010M

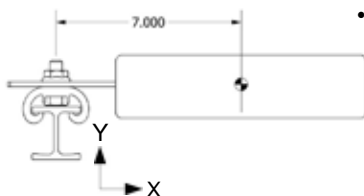
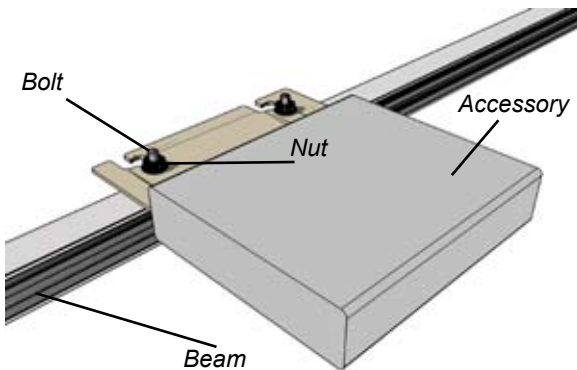

Dimensions specified in inches unless noted

- **Slider Material:** One of the following mill finished extruded aluminum alloys: 6005-T5, 6105-T5, 6061-T6  
**Ultimate Tensile:** 38 ksi, **Yield:** 35 ksi
- **Slider Weight:** 0.026 lbs (12g)
- Allowable and design loads are valid when components are assembled with SolarMount-I 1.0 or 2.5 Beams according to authorized UNIRAC documents
- SolarMount-I Series Accessory Mounts are compatible with SolarMount-I Beams
- Use two Accessory Mounts per accessory
- **Assemble each pair of clamps with the following stainless steel hardware:** two ¼-20 set screws, two ¼-20 heavy hex jam nuts, and two ¼-20 F594 serrated flange nuts
- Use anti-seize and tighten to 5-10 ft-lbs of torque
- Resistance factors and safety factors are determined according calculations and UNIRAC testing

Maximum distance of accessory center of gravity from beam center in (mm)	Maximum weight of accessory lbs (kg)
7 (178)	32 (14.5)

## SolarMount-I Beam Connection Hardware

### SolarMount-I 1- Flange Foot Part No. 04011M

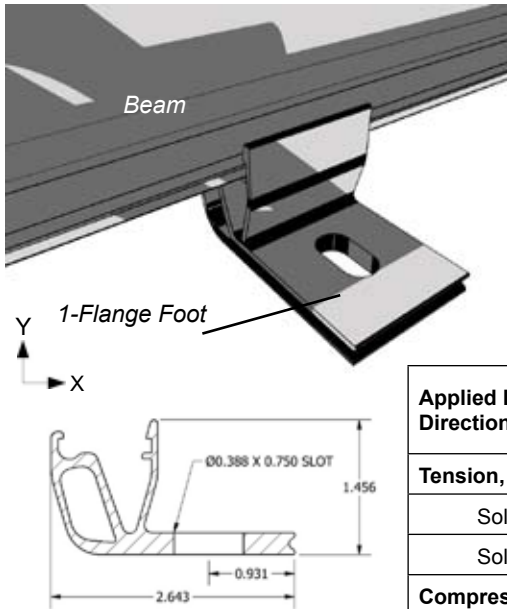

Dimensions specified in inches unless noted

- **1-Flange Foot Material:** One of the following mill finished extruded aluminum alloys: 6005-T5, 6105-T5, 6061-T6  
**Ultimate Tensile:** 38 ksi, **Yield:** 35 ksi
- **1-Flange Foot Weight:** 0.101 lbs (46 g)
- Allowable and design loads are valid when components are assembled with SolarMount-I 1.0 or 2.5 Beams according to authorized UNIRAC documents
- 1-Flange feet are compatible with SolarMount-I Beams
- Resistance factors and safety factors are determined according to part 1 section 9 of the 2005 Aluminum Design Manual
- Design and allowable loads are for the beam to foot connection
- **Be sure to check load limits for roof attachments and standoffs**

Applied Load Direction	Average Ultimate lbs (N)	Allowable Load lbs (N)	Safety Factor, FS	Design Load lbs (N)	Resistance Factor, $\Phi$
<b>Tension, Y+</b>					
SolarMount-I 1.0 Beam	1388 (5952)	591 (2629)	2.26	894 (3977)	0.668
SolarMount-I 2.5 Beam	1514 (6735)	648 (2882)	2.34	980 (4359)	0.647
<b>Compression, Y-</b>					
SolarMount-I 1.0 Beam	2931 (13038)	1288 (5729)	2.28	1948 (8665)	0.664
SolarMount-I 2.5 Beam	2750 (12233)	1223 (5440)	2.25	1849 (8225)	0.672
<b>Transverse, X-, downhill</b>					
	635 (2825)	313 (1392)	2.03	473 (2104)	0.745
<b>Transverse, X+, uphill</b>					
	42 (187)	20 (89)	2.15	30 (133)	0.705
<b>Sliding, Z±</b>					
	(see Beam Splice)				

### SolarMount-I 2 - Flange Foot Part No. 04002M, 04003M

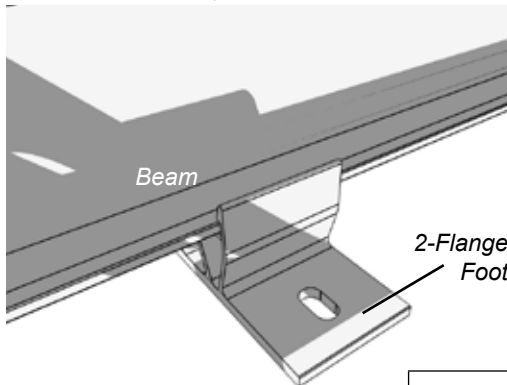

Dimensions specified in inches unless noted

- **2-Flange Foot Material:** One of the following mill finished extruded aluminum alloys: 6005-T5, 6105-T5, 6061-T6  
**Ultimate Tensile:** 38 ksi, **Yield:** 35 ksi
- **2-Flange Foot Weight:** 0.103 lbs (47 g)
- Allowable and design loads are valid when components are assembled with SolarMount-I 1.0 or 2.5 Beams according to authorized UNIRAC documents
- 2-Flange Feet are compatible with SolarMount-I Beams
- Resistance factors and safety factors are determined according to part 1 section 9 of the 2005 Aluminum Design Manual
- Design and allowable loads are for the beam to foot connection
- **Be sure to check load limits for roof attachments and standoffs**

Applied Load Direction	Average Ultimate lbs (N)	Allowable Load lbs (N)	Safety Factor, FS	Design Load lbs (N)	Resistance Factor, $\Phi$
<b>Tension, Y+</b>					
SolarMount-I 1.0 Beam	1931 (8950)	864 (3843)	2.23	1307 (5814)	0.667
SolarMount-I 2.5 Beam	2478 (11023)	1111 (4942)	2.23	1681 (7477)	0.678
<b>Compression, Y-</b>					
SolarMount-I 1.0 Beam	3788 (16850)	1706 (7589)	2.22	2581 (11481)	0.681
SolarMount-I 2.5 Beam	3694 (16432)	1562 (6948)	2.36	2363 (10511)	0.640
<b>Transverse, X-, downhill</b>					
	635 (2825)	313 (1392)	2.03	473 (2104)	0.745
<b>Transverse, X+, uphill</b>					
	42 (187)	20 (89)	2.15	30 (133)	0.705
<b>Sliding, Z±</b>					
	(see Beam Splice)				

## SolarMount-I Beam Connection Hardware

### SolarMount-I Beam Splice Part No. 03020M, 03021M

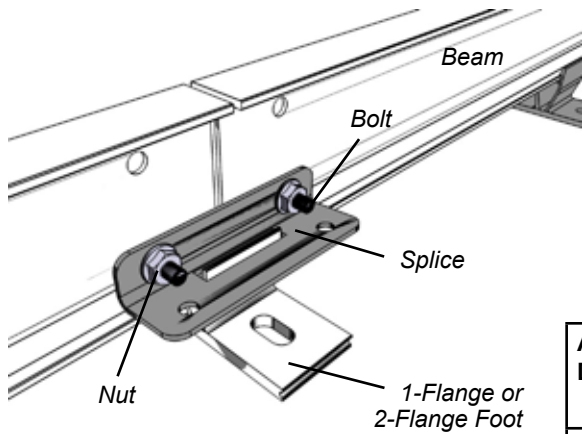

- **Beam Splice Material:** Aluminum 5052-H32  
**Ultimate Tensile:** 31 ksi, Yield: 23 ksi
- **Beam Splice Weight:** 0.053 lbs (24 g)
- Allowable and design loads are valid when components are assembled according to authorized UNIRAC documents
- Beam Splices are compatible with SolarMount-I Beams when used with 1-Flange or 2-Flange feet
- Resistance factors and safety factors are determined according to part 1 section 9 of the 2005 Aluminum Design Manual

Applied Load Direction	Average Ultimate lbs (N)	Allowable Load lbs (N)	Safety Factor, FS	Design Load lbs (N)	Resistance Factor, $\Phi$
Sliding, $\pm$	1428 (6352)	620 (2758)	2.30	938 (4172)	0.657

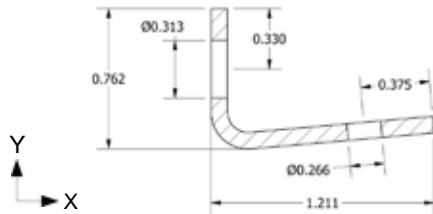

Dimensions specified in inches unless noted

## SolarMount-I Beam

<b>MATERIAL: One of the following extruded aluminum alloys: 6005-T5, 6105-T5, or 6061-T6, Mill Finish</b>			
Properties	Units	Beam Height (in)	
		1.094	2.500
Approximate Weight (per linear ft)	plf	0.356	0.548
Total Cross Sectional Area	in <sup>2</sup>	0.3037	0.4665
Section Modulus (X-Axis)	in <sup>3</sup>	0.1101	0.3687
Section Modulus (Y-Axis)	in <sup>3</sup>	0.0390	0.0422
Moment of Inertia (X-Axis)	in <sup>4</sup>	0.0602	0.4609
Moment of Inertia (Y-Axis)	in <sup>4</sup>	0.0195	0.0211
Radius of Gyration (X-Axis)	in	0.4453	0.9940
Radius of Gyration (Y-Axis)	in	0.2536	0.2127

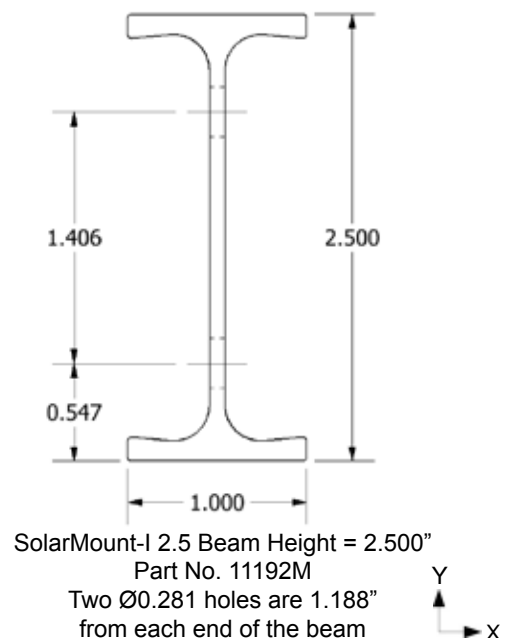
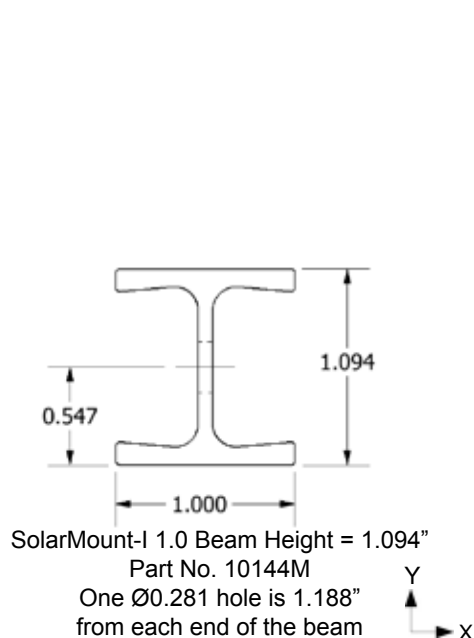

Dimensions specified in inches unless noted



## UNIRAC SolarMount-I 1.0 Engineering Report, Page 1 of 2

### 90 mph Wind Chart

Module Size	Max Span (inches)			
	Ground Snow 0	20	30	40
<b>52" x 35"</b>	56 229/ 262/ 54	52 211/ 305/ 96	48 197/ 327/ 123	44 177/ 364/ 140
<b>65" x 40"</b>	49 250/ 286/ 58	44 222/ 321/ 101	41 207/ 345/ 129	37 186/ 384/ 148
<b>77" x 51"</b>	40 238/ 273/ 56	35 212/ 307/ 96	33 198/ 329/ 123	30 178/ 366/ 141

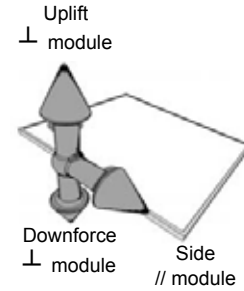

### 110 mph Wind Chart

Module Size	Max Span (inches)			
	Ground Snow 0	20	30	40
<b>52" x 35"</b>	49 305/ 323/ 47	48 295/ 334/ 88	45 277/ 356/ 113	42 261/ 377/ 136
<b>65" x 40"</b>	41 321/ 340/ 49	40 311/ 352/ 92	38 292/ 375/ 119	36 275/ 397/ 143
<b>77" x 51"</b>	33 306/ 325/ 47	32 297/ 336/ 88	30 278/ 358/ 113	29 263/ 379/ 136

### Know your limits!

Check attachment load limits.

### 120 mph Wind Chart

Module Size	Max Span (inches)			
	Ground Snow 0	20	30	40
<b>52" x 35"</b>	45 337/ 350/ 43	45 334/ 353/ 83	42 315/ 374/ 107	40 299/ 394/ 130
<b>65" x 40"</b>	38 355/ 369/ 45	38 352/ 372/ 87	36 332/ 394/ 113	34 315/ 415/ 137
<b>77" x 51"</b>	31 339/ 352/ 43	30 336/ 355/ 83	29 317/ 376/ 108	27 301/ 396/ 130

### 150 mph Wind Chart

Module Size	Max Span (inches)			
	Ground Snow 0	20	30	40
<b>52" x 35"</b>	37 432/ 427/ 35	37 432/ 427/ 68	37 432/ 432/ 93	35 415/ 449/ 114
<b>65" x 40"</b>	31 455/ 450/ 37	31 455/ 450/ 71	31 455/ 455/ 98	30 438/ 473/ 120
<b>77" x 51"</b>	25 434/ 429/ 35	25 434/ 429/ 68	25 434/ 434/ 93	24 418/ 452/ 114

Installation of products related to this engineering report is subject to the requirements below:

- Flush roof installations only; modules must be < 10" from roof surface
- The building has either a flat roof, a gable roof ≤ 45°, or a hip roof ≤ 27°
- The roof has a minimum slope of 1.2°
- Installation must have at least 4 modules grouped together (minimum 50 ft<sup>2</sup>)
- Surrounding ground area must not slope more than 10 degrees
- Location must fall into Wind Exposure Category B or C
- Building height must be less than or equal to 30 feet
- For roof zones 2 and 3 use 1/2 Max Span
- Max cantilever = 1/3 Max Span
- Ground snow loads are adjusted for roof slope and temperature based on ASCE 7-05
- Long edge of module must be perpendicular to the beam
- The installer must comply with the responsibilities and instructions described in the install manual
- The installer must confirm that the method of attachment (components and hardware) and structure can handle the given point loads
- In regions with ground snow loads less than 20 psf but not zero, the roof angle in degrees must be greater than the horizontal distance from eave to ridge / 50
- System dead load, including modules and mounting hardware, must be between 2 and 3.5 psf.
- Importance factors are equal to 1.0 in all cases.
- Unbalanced and drift snow loads have not been considered.
- Installations must be in seismic site class A, B, C, or D
- Spectral response acceleration, S<sub>s</sub>, is ≤ 1.5 (and ≤ 0.35 if snow loads are ≥ 30 psf).



UNIRAC SolarMount-I 1.0 Engineering Report, Page 2 of 2

**Engineering Variables**

Description	Variable	Value	Units
Building Height	h	30	ft
Roof Pitch		0-45	degrees
Wind Exposure Category		C	
Importance Factor	I	1	
Effective Wind Area		50+	ft <sup>2</sup>
Topographic Factor	Kzt	1	
Roof Zone		1	(use 1/2 span for zones 2 and 3)

**Design Wind Loads**

Basic Wind Speed (mph)	<u>90</u>	<u>110</u>	<u>120</u>	<u>150</u>
Max Design Wind Load, Pnet; Uplift (psf)	-19.2	-28.7	-34.2	-53.3
Max Design Wind Load, Pnet; Downforce (psf)	17.5	26.0	31.1	48.4

**Dead, Snow, and Earthquake Loads**

Dead Load; min/ max	2 / 3.5	psf		
Earthquake Load	2.8	psf		
Ground Snow Load, Pg, (pounds/ ft <sup>2</sup> )	<u>0</u>	<u>20</u>	<u>30</u>	<u>40</u>
Max Sloped roof snow load (psf)	0.0	20.0	25.2	33.6
Max Distance between splices (inches, feet)	653, 54	336, 28	245, 20	193, 16

**Distributed Loads for 65" x 40" module, pounds/ inch  
(smaller modules -20%, larger modules +18%)**

Wind Load (mph)	Ground Snow Load (psf)				
	0	20	30	40	
<u>90</u>	4.06	4.06	4.06	4.06	Uplift, ⊥ to module
	4.65	5.87	6.75	8.37	Downforce, ⊥ to module
	0.95	1.84	2.53	3.22	Side, // module
<u>110</u>	6.21	6.21	6.21	6.21	Uplift, ⊥ to module
	6.57	7.02	7.98	8.94	Downforce, ⊥ to module
	0.95	1.84	2.53	3.22	Side, // module
<u>120</u>	7.44	7.44	7.44	7.44	Uplift, ⊥ to module
	7.71	7.88	8.83	9.79	Downforce, ⊥ to module
	0.95	1.84	2.53	3.22	Side, // module
<u>150</u>	11.77	11.77	11.77	11.77	Uplift, ⊥ to module
	11.63	11.63	11.77	12.73	Downforce, ⊥ to module
	0.95	1.84	2.53	3.22	Side, // module

⊥ : perpendicular/ normal  
// : parallel

**For installations that do not comply with the limitations on page 1, refer to [www.unirac.com](http://www.unirac.com) for an engineering design guide to manually calculate loads or contact your distributor.**

The design is based on and in compliance with the following codes/standards:

1. 2003 International Building Code, by International Code Council , Inc., 2003.
2. 2006 International Building Code, by International Code Council , Inc., 2006.
3. Aluminum Design Manual: Specifications and Guidelines for Aluminum Structures, by The Aluminum Association, Washington, D.C., 2005.
4. 2007 California Building Code (CBC), based on the 2006 International Building Code, by International Code Council , Inc., 2006.



## UNIRAC SolarMount-I 2.5 Engineering Report, Page 1 of 2

### 90 mph Wind Chart

Module Size	Max Span (inches)			
	Ground Snow 0	20	30	40
<b>52" x 35"</b>	76 310/ 355/ 73	67 271/ 392/ 123	57 231/ 385/ 144	51 205/ 423/ 163
<b>65" x 40"</b>	63 319/ 365/ 75	56 284/ 410/ 129	51 259/ 430/ 161	45 229/ 473/ 182
<b>77" x 51"</b>	50 300/ 344/ 70	44 267/ 386/ 121	41 249/ 414/ 155	37 224/ 461/ 177

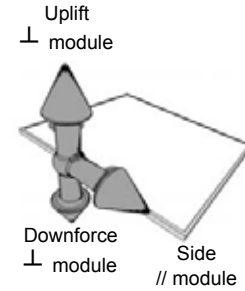

### 110 mph Wind Chart

Module Size	Ground Snow			
	0	20	30	40
<b>52" x 35"</b>	64 399/ 423/ 61	62 386/ 437/ 115	57 354/ 455/ 144	51 314/ 452/ 163
<b>65" x 40"</b>	53 410/ 434/ 63	51 397/ 449/ 118	48 372/ 479/ 152	45 351/ 505/ 182
<b>77" x 51"</b>	42 386/ 409/ 59	41 373/ 422/ 111	38 350/ 450/ 143	36 331/ 477/ 172

### Know your limits!

Check attachment load limits.

### 120 mph Wind Chart

Module Size	Ground Snow			
	0	20	30	40
<b>52" x 35"</b>	59 442/ 458/ 56	59 437/ 463/ 108	55 413/ 490/ 140	51 376/ 495/ 163
<b>65" x 40"</b>	49 454/ 470/ 58	48 449/ 475/ 111	46 424/ 503/ 144	43 403/ 530/ 174
<b>77" x 51"</b>	39 427/ 443/ 55	38 423/ 447/ 105	36 399/ 474/ 136	34 379/ 499/ 164

### 150 mph Wind Chart

Module Size	Ground Snow			
	0	20	30	40
<b>52" x 35"</b>	48 566/ 559/ 46	48 566/ 559/ 89	48 565/ 566/ 122	46 544/ 588/ 149
<b>65" x 40"</b>	40 581/ 574/ 47	40 581/ 574/ 91	39 581/ 581/ 125	38 559/ 604/ 153
<b>77" x 51"</b>	31 547/ 540/ 44	31 547/ 540/ 86	31 547/ 547/ 118	30 526/ 569/ 144

Installation of products related to this engineering report is subject to the requirements below:

- Flush roof installations only; modules must be < 10" from roof surface
- The building has either a flat roof, a gable roof ≤ 45°, or a hip roof ≤ 27°
- The roof has a minimum slope of 1.2°
- Installation must have at least 4 modules grouped together (minimum 50 ft<sup>2</sup>)
- Surrounding ground area must not slope more than 10 degrees
- Location must fall into Wind Exposure Category B or C
- Building height must be less than or equal to 30 feet
- For roof zones 2 and 3 use 1/2 Max Span
- Max cantilever = 1/3 Max Span
- Ground snow loads are adjusted for roof slope and temperature based on ASCE 7-05
- Long edge of module must be perpendicular to the beam
- The installer must comply with the responsibilities and instructions described in the install manual
- The installer must confirm that the method of attachment (components and hardware) and structure can handle the given point loads
- In regions with ground snow loads less than 20 psf but not zero, the roof angle in degrees must be greater than the horizontal distance from eave to ridge / 50
- System dead load, including modules and mounting hardware, must be between 2 and 3.5 psf.
- Importance factors are equal to 1.0 in all cases.
- Unbalanced and drift snow loads have not been considered.
- Installations must be in seismic site class A, B, C, or D
- Spectral response acceleration,  $S_s$ , is ≤ 1.5 (and ≤ 0.35 if snow loads are ≥ 30 psf).



UNIRAC SolarMount-I 2.5 Engineering Report, Page 2 of 2

**Engineering Variables**

Description	Variable	Value	Units
Building Height	h	30	ft
Roof Pitch		0-45	degrees
Wind Exposure Category		C	
Importance Factor	I	1	
Effective Wind Area		50+	ft <sup>2</sup>
Topographic Factor	Kzt	1	
Roof Zone		1	(use 1/2 span for zones 2 and 3)

**Design Wind Loads**

Basic Wind Speed (mph)	<u>90</u>	<u>110</u>	<u>120</u>	<u>150</u>
Max Design Wind Load, Pnet; Uplift (psf)	-19.2	-28.7	-34.2	-53.3
Max Design Wind Load, Pnet; Downforce (psf)	17.5	26.0	31.1	48.4

**Dead, Snow, and Earthquake Loads**

Dead Load; min/ max	2 / 3.5	psf		
Earthquake Load	2.8	psf		
Ground Snow Load, Pg, (pounds/ ft <sup>2</sup> )	<u>0</u>	<u>20</u>	<u>30</u>	<u>40</u>
Max Sloped roof snow load (psf)	0.0	20.0	25.2	33.6
Max Distance between splices (inches, feet)	653, 54	336, 28	245, 20	193, 16

**Distributed Loads for 65" x 40" module, pounds/ inch  
(smaller modules -20%, larger modules +18%)**

		Ground Snow Load (psf)				
		0	20	30	40	
	Wind Load (mph)					
	<u>90</u>	4.06	4.06	4.06	4.06	Uplift, ⊥ to module
		4.65	5.87	6.75	8.37	Downforce, ⊥ to module
		0.95	1.84	2.53	3.22	Side, // module
	<u>110</u>	6.21	6.21	6.21	6.21	Uplift, ⊥ to module
		6.57	7.02	7.98	8.94	Downforce, ⊥ to module
		0.95	1.84	2.53	3.22	Side, // module
	<u>120</u>	7.44	7.44	7.44	7.44	Uplift, ⊥ to module
		7.71	7.88	8.83	9.79	Downforce, ⊥ to module
		0.95	1.84	2.53	3.22	Side, // module
	<u>150</u>	11.77	11.77	11.77	11.77	Uplift, ⊥ to module
		11.63	11.63	11.77	12.73	Downforce, ⊥ to module
	0.95	1.84	2.53	3.22	Side, // module	

⊥ : perpendicular/ normal  
// : parallel

**For installations that do not comply with the limitations on page 1, refer to [www.unirac.com](http://www.unirac.com) for an engineering design guide to manually calculate loads or contact your distributor.**

The design is based on and in compliance with the following codes/standards:

1. 2003 International Building Code, by International Code Council , Inc., 2003.
2. 2006 International Building Code, by International Code Council , Inc., 2006.
3. Aluminum Design Manual: Specifications and Guidelines for Aluminum Structures, by The Aluminum Association, Washington, D.C., 2005.
4. 2007 California Building Code (CBC), based on the 2006 International Building Code, by International Code Council , Inc., 2006.