

# SUNFRAME®

## Code-Compliant Installation Manual 809



# Unirac Code-Compliant Installation Manual

### Table of Contents

---

i. Installer's Responsibilities .....	2
Part I. Procedure to Determine the Total Design Wind Load .....	3
Part II. Procedure to Select Rail Span and Rail Type .....	10
Part III. Installing SunFrame .....	14

---



Unirac welcomes input concerning the accuracy and user-friendliness of this publication. Please write to [publications@unirac.com](mailto:publications@unirac.com).

Pub 101020-1cc  
October 2010

© 2010 by Unirac, Inc.  
All rights reserved.

## i. Installer's Responsibilities

Please review this manual thoroughly before installing your SunFrame system.

This manual provides (1) supporting documentation for building permit applications relating to Unirac's SunFrame Universal PV Module Mounting system, and (2) planning and assembly instructions for SunFrame

SunFrame products, when installed in accordance with this bulletin, will be structurally adequate and will meet the structural requirements of the IBC 2006, IBC 2003, ASCE 7-02, ASCE 7-05 and California Building Code 2007 (collectively referred to as "the Code"). Unirac also provides a limited warranty on SunFrame products (page 24).

SunFrame offers finish choices and low, clean lines that become as natural a part of a home as a skylight. It delivers the installation ease you've come to expect from Unirac.

Whether for pitched roofs and parking roof structures, SunFrame was designed from the outset to promote superior aesthetics. Modules are flush mounted in low, gap-free rows, and visible components match clear or dark module frames.



### **The installer is solely responsible for:**

- Complying with all applicable local or national building codes, including any that may supersede this manual;
- Ensuring that Unirac and other products are appropriate for the particular installation and the installation environment;
- Ensuring that the roof, its rafters, connections, and other structural support members can support the array under all code level loading conditions (this total building assembly is referred to as the building structure);
- Using only Unirac parts and installer-supplied parts as specified by Unirac (substitution of parts may void the warranty and invalidate the letters of certification in all Unirac publications);
- Ensuring that lag screws have adequate pullout strength and shear capacities as installed;
- Verifying the strength of any alternate mounting used in lieu of the lag screws;
- Maintaining the waterproof integrity of the roof, including selection of appropriate flashing;
- Ensuring safe installation of all electrical aspects of the PV array;
- Ensuring correct and appropriate design parameters are used in determining the design loading used for design of the specific installation. Parameters, such as snow loading, wind speed, exposure and topographic factor should be confirmed with the local building official or a licensed professional engineer.

## Part I. Procedure to Determine the Design Wind Load

### [1.1.] Using the Simplified Method - ASCE 7-05:

The procedure to determine Design Wind Load is specified by the American Society of Civil Engineers and referenced in the International Building Code 2006 and 2009. For purposes of this document, the values, equations and procedures used in this document reference ASCE 7-05, Minimum Design Loads for Buildings and Other Structures. **Please refer to ASCE 7-05 if you have any questions about the definitions or procedures presented in this manual.** Unirac uses Method 1, the Simplified Method, for calculating the Design Wind Load for pressures on components and cladding in this document.

The method described in this document is valid for flush, no tilt, SunFrame Series applications on either roofs or walls. Flush is defined as panels parallel to the surface (or with no more than 3" difference between ends of assembly) with no more than 10" space between the roof surface, and the bottom of the PV panels.

This method is not approved for open structure calculations. **Applications of these procedures is subject to the following ASCE 7-05 limitations:**

1. The building height must be less than 60 feet,  $h < 60$ . See note for determining  $h$  in the next section. For installations on structures greater than 60 feet, contact your local Unirac Distributor.
2. The building must be enclosed, not an open or partially enclosed structure, for example a carport.
3. The building is regular shaped with no unusual geometrical irregularity in spatial form, for example a geodesic dome.
4. The building is not in an extreme geographic location such as a narrow canyon or steep cliff.
5. The building has a flat or gable roof with a pitch less than 45 degrees or a hip roof with a pitch less than 27 degrees.
6. If your installation does not conform to these requirements please contact your local Unirac distributor, a local professional engineer or Unirac

If your installation is outside the United States or does not meet all of these limitations, consult a local professional engineer or your local building authority. Consult ASCE 7-05

for more clarification on the use of Method I. Lower design wind loads may be obtained by applying Method II from ASCE 7-05. Consult with a licensed engineer if you want to use Method II procedures.

**The equation for determining the Design Wind Load for components and cladding is:**

$$p_{net} (psf) = \lambda K_{zt} I p_{net30}$$

$p_{net} (psf) =$  Design Wind Load

$\lambda =$  adjustment factor for height and exposure category

$K_{zt} =$  Topographic Factor at mean roof height,  $h$  (ft)

$I =$  Importance Factor

$p_{net30} (psf) =$  net design wind pressure for Exposure B, at height = 30,  $I = 1$

**You will also need to know the following information:**

*Basic Wind Speed =  $V$  (mph), the largest 3 second gust of wind in the last 50 years.*

*$h$  (ft) = total roof height for flat roof buildings or mean roof height for pitched roof buildings*

*Effective Wind Area (sf) = minimum total continuous area of modules being installed*

*Roof Zone = the area of the roof you are installing the pv system according to Figure 2, page 5.*

*Roof Zone Setback Length =  $a$  (ft)*

*Roof Pitch (degrees)*

*Exposure Category*

### [1.2.] Procedure to Calculate Total Design Wind:

The procedure for determining the Design Wind Load can be broken into steps that include looking up several values in different tables.

#### **Step 1: Determine Basic Wind Speed, $V$ (mph):**

Determine the *Basic Wind Speed,  $V$  (mph)* by consulting your local building department or locating your installation on the maps in **Figure 1, page 4.**

#### **Step 2: Determining Effective Wind Area:**

Determine the smallest area of continuous modules you will be installing. This is the smallest area tributary (contributing load) to a support or to a simple-span of rail. That area is the Effective Wind Area.

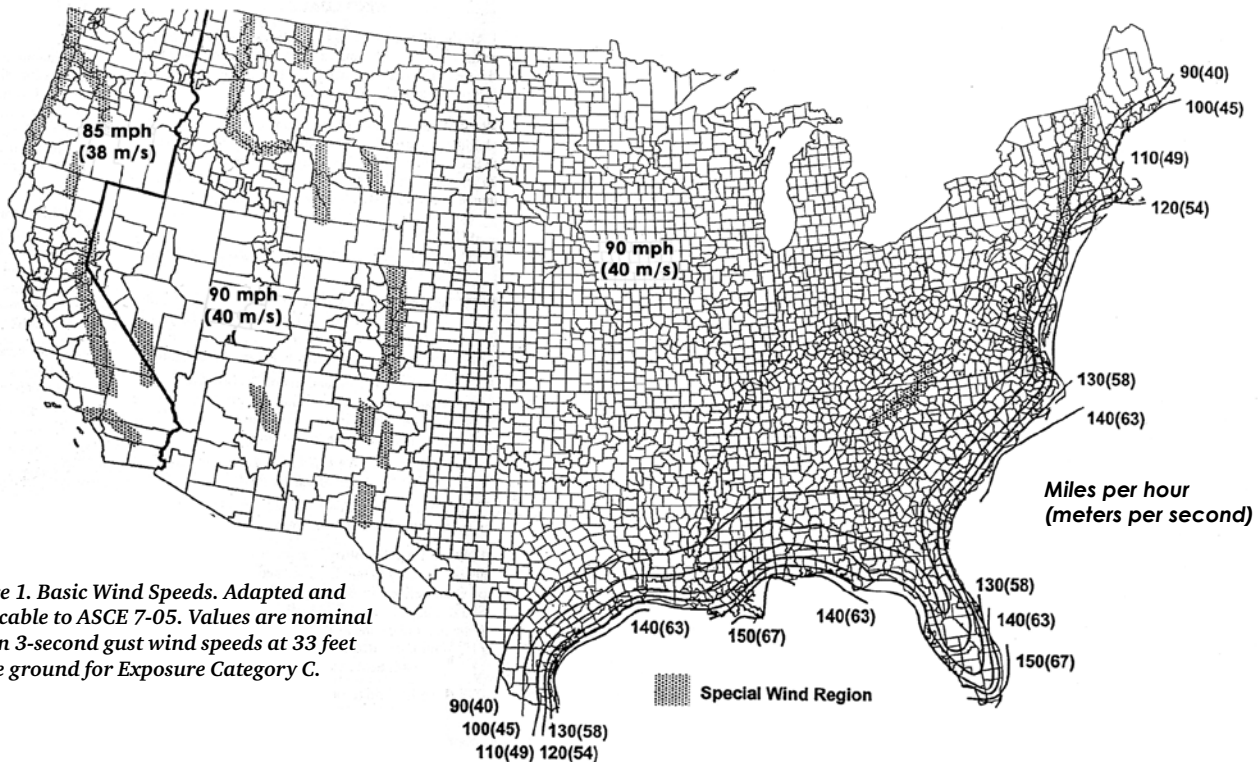

Figure 1. Basic Wind Speeds. Adapted and applicable to ASCE 7-05. Values are nominal design 3-second gust wind speeds at 33 feet above ground for Exposure Category C.

**Step 3: Determine Roof/Wall Zone:**

The Design Wind Load will vary based on where the installation is located on a roof. Arrays may be located in more than one roof zone.

Using Table 1, determine the Roof Zone Setback Length, *a* (ft), according to the width and height of the building on which you are installing the pv system.

Table 1. Determine Roof/Wall Zone, length (*a*) according to building width and height

*a* = 10 percent of the least horizontal dimension or 0.4h, whichever is smaller, but not less than either 4% of the least horizontal dimension or 3 ft of the building.

Roof Height (ft)	Least Horizontal Dimension (ft)																		
	10	15	20	25	30	40	50	60	70	80	90	100	125	150	175	200	300	400	500
10	3	3	3	3	3	4	4	4	4	4	4	4	5	6	7	8	12	16	20
15	3	3	3	3	3	4	5	6	6	6	6	6	6	6	7	8	12	16	20
20	3	3	3	3	3	4	5	6	7	8	8	8	8	8	8	8	12	16	20
25	3	3	3	3	3	4	5	6	7	8	9	10	10	10	10	10	12	16	20
30	3	3	3	3	3	4	5	6	7	8	9	10	12	12	12	12	12	16	20
35	3	3	3	3	3	4	5	6	7	8	9	10	12.5	14	14	14	14	16	20
40	3	3	3	3	3	4	5	6	7	8	9	10	12.5	15	16	16	16	16	20
45	3	3	3	3	3	4	5	6	7	8	9	10	12.5	15	17.5	18	18	18	20
50	3	3	3	3	3	4	5	6	7	8	9	10	12.5	15	17.5	20	20	20	20
60	3	3	3	3	3	4	5	6	7	8	9	10	12.5	15	17.5	20	24	24	24

Source: ASCE/SEI 7-05, Minimum Design Loads for Buildings and Other Structures, Chapter 6, Figure 6-3, p. 41.

**Step 3: Determine Roof Zone (continued):**

Using *Roof Zone Setback Length, a*, determine the roof zone locations according to your roof type, gable, hip or monoslope. Determine in which roof zone your pv system is located, Zone 1, 2, or 3 according to **Figure 2**.

Figure 2. Enclosed buildings, wall and roofs

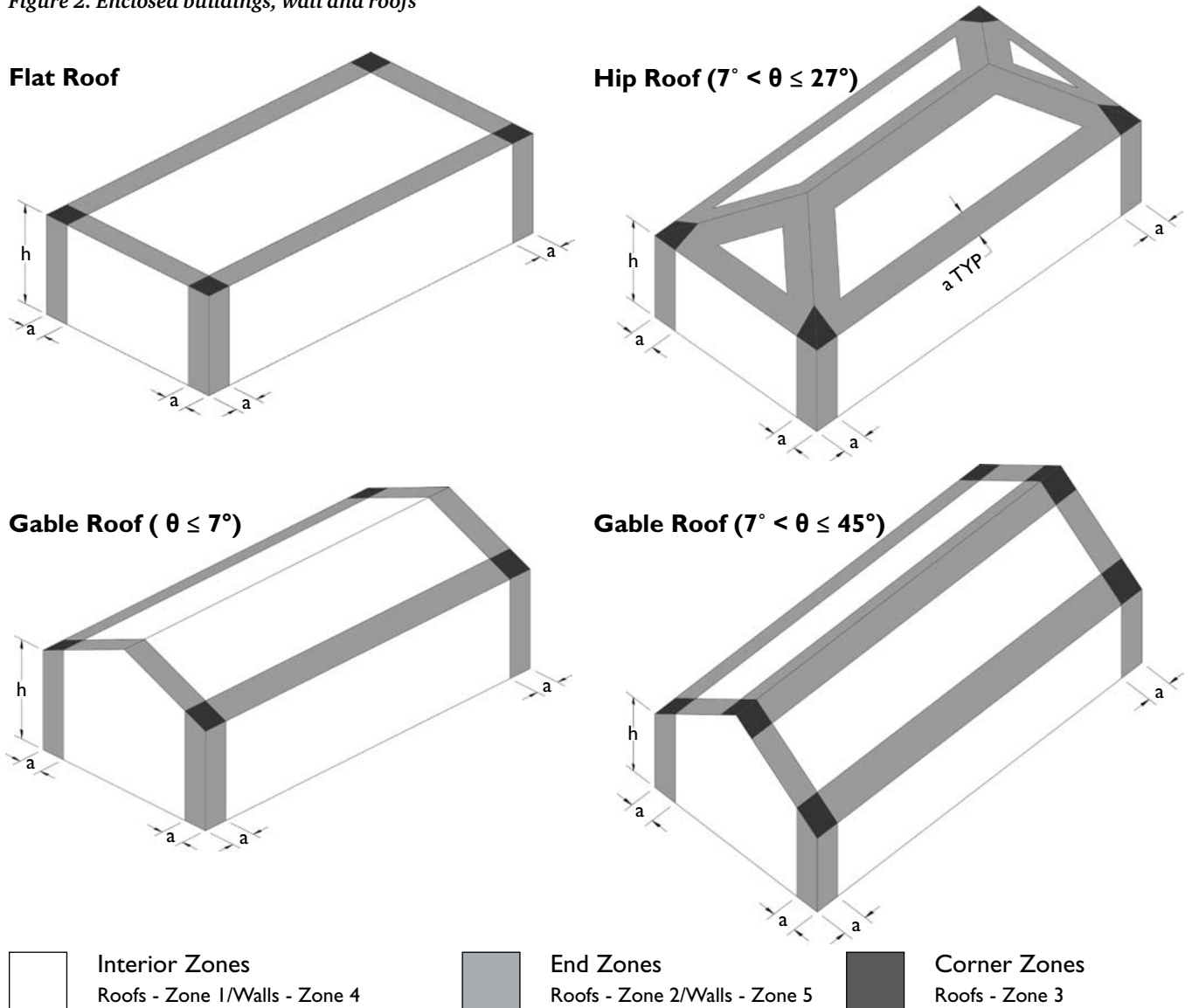

Source: ASCE/SEI 7-05, *Minimum Design Loads for Buildings and Other Structures*, Chapter 6, p. 41.

**Step 4: Determine Net Design Wind Pressure,  $P_{net30}$  (psf):**

Using the *Effective Wind Area* (Step 2), *Roof Zone Location* (Step 3), and *Basic Wind Speed* (Step 1), look up the appropriate *Net Design Wind Pressure* in **Table 2, page 6**. Use the *Effective Wind Area* value in the table which is smaller than the value calculated in **Step 2**. If the installation is located on a roof overhang, use **Table 3, page 7**.

Both downforce and uplift pressures must be considered in overall design. Refer to Section II, Step 1 for applying downforce and uplift pressures. Positive values are acting toward the surface. Negative values are acting away from the surface.

Table 2.  $p_{net30}$  (psf) Roof and Wall

		Basic Wind Speed, V (mph)																
Zone	Effective Wind Area (sf)	90		100		110		120		130		140		150		170		
		Downforce	Uplift	Downforce	Uplift	Downforce	Uplift	Downforce	Uplift	Downforce	Uplift	Downforce	Uplift	Downforce	Uplift	Downforce	Uplift	
Roof 0 to 7 degrees	1	10	5.9	-14.6	7.3	-18.0	8.9	-21.8	10.5	-25.9	12.4	-30.4	14.3	-35.3	16.5	-40.5	21.1	-52.0
		20	5.6	-14.2	6.9	-17.5	8.3	-21.2	9.9	-25.2	11.6	-29.6	13.4	-34.4	15.4	-39.4	19.8	-50.7
		50	5.1	-13.7	6.3	-16.9	7.6	-20.5	9.0	-24.4	10.6	-28.6	12.3	-33.2	14.1	-38.1	18.1	-48.9
		100	4.7	-13.3	5.8	-16.5	7.0	-19.9	8.3	-23.7	9.8	-27.8	11.4	-32.3	13.0	-37.0	16.7	-47.6
	2	10	5.9	-24.4	7.3	-30.2	8.9	-36.5	10.5	-43.5	12.4	-51.0	14.3	-59.2	16.5	-67.9	21.1	-87.2
		20	5.6	-21.8	6.9	-27.0	8.3	-32.6	9.9	-38.8	11.6	-45.6	13.4	-52.9	15.4	-60.7	19.8	-78.0
		50	5.1	-18.4	6.3	-22.7	7.6	-27.5	9.0	-32.7	10.6	-38.4	12.3	-44.5	14.1	-51.1	18.1	-65.7
		100	4.7	-15.8	5.8	-19.5	7.0	-23.6	8.3	-28.1	9.8	-33.0	11.4	-38.2	13.0	-43.9	16.7	-56.4
	3	10	5.9	-36.8	7.3	-45.4	8.9	-55.0	10.5	-65.4	12.4	-76.8	14.3	-89.0	16.5	-102.2	21.1	-131.3
		20	5.6	-30.5	6.9	-37.6	8.3	-45.5	9.9	-54.2	11.6	-63.6	13.4	-73.8	15.4	-84.7	19.8	-108.7
		50	5.1	-22.1	6.3	-27.3	7.6	-33.1	9.0	-39.3	10.6	-46.2	12.3	-53.5	14.1	-61.5	18.1	-78.9
		100	4.7	-15.8	5.8	-19.5	7.0	-23.6	8.3	-28.1	9.8	-33.0	11.4	-38.2	13.0	-43.9	16.7	-56.4
Roof 7 to 27 degrees	1	10	8.4	-13.3	10.4	-16.5	12.5	-19.9	14.9	-23.7	17.5	-27.8	20.3	-32.3	23.3	-37.0	30.0	-47.6
		20	7.7	-13.0	9.4	-16.0	11.4	-19.4	13.6	-23.0	16.0	-27.0	18.5	-31.4	21.3	-36.0	27.3	-46.3
		50	6.7	-12.5	8.2	-15.4	10.0	-18.6	11.9	-22.2	13.9	-26.0	16.1	-30.2	18.5	-34.6	23.8	-44.5
		100	5.9	-12.1	7.3	-14.9	8.9	-18.1	10.5	-21.5	12.4	-25.2	14.3	-29.3	16.5	-33.6	21.1	-43.2
	2	10	8.4	-23.2	10.4	-28.7	12.5	-34.7	14.9	-41.3	17.5	-48.4	20.3	-56.2	23.3	-64.5	30.0	-82.8
		20	7.7	-21.4	9.4	-26.4	11.4	-31.9	13.6	-38.0	16.0	-44.6	18.5	-51.7	21.3	-59.3	27.3	-76.2
		50	6.7	-18.9	8.2	-23.3	10.0	-28.2	11.9	-33.6	13.9	-39.4	16.1	-45.7	18.5	-52.5	23.8	-67.4
		100	5.9	-17.0	7.3	-21.0	8.9	-25.5	10.5	-30.3	12.4	-35.6	14.3	-41.2	16.5	-47.3	21.1	-60.8
	3	10	8.4	-34.3	10.4	-42.4	12.5	-51.3	14.9	-61.0	17.5	-71.6	20.3	-83.1	23.3	-95.4	30.0	-122.5
		20	7.7	-32.1	9.4	-39.6	11.4	-47.9	13.6	-57.1	16.0	-67.0	18.5	-77.7	21.3	-89.2	27.3	-114.5
		50	6.7	-29.1	8.2	-36.0	10.0	-43.5	11.9	-51.8	13.9	-60.8	16.1	-70.5	18.5	-81.0	23.8	-104.0
		100	5.9	-26.9	7.3	-33.2	8.9	-40.2	10.5	-47.9	12.4	-56.2	14.3	-65.1	16.5	-74.8	21.1	-96.0
Roof 27 to 45 degrees	1	10	13.3	-14.6	16.5	-18.0	19.9	-21.8	23.7	-25.9	27.8	-30.4	32.3	-35.3	37.0	-40.5	47.6	-52.0
		20	13.0	-13.8	16.0	-17.1	19.4	-20.7	23.0	-24.6	27.0	-28.9	31.4	-33.5	36.0	-38.4	46.3	-49.3
		50	12.5	-12.8	15.4	-15.9	18.6	-19.2	22.2	-22.8	26.0	-26.8	30.2	-31.1	34.6	-35.7	44.5	-45.8
		100	12.1	-12.1	14.9	-14.9	18.1	-18.1	21.5	-21.5	25.2	-25.2	29.3	-29.3	33.6	-33.6	43.2	-43.2
	2	10	13.3	-17.0	16.5	-21.0	19.9	-25.5	23.7	-30.3	27.8	-35.6	32.3	-41.2	37.0	-47.3	47.6	-60.8
		20	13.0	-16.3	16.0	-20.1	19.4	-24.3	23.0	-29.0	27.0	-34.0	31.4	-39.4	36.0	-45.3	46.3	-58.1
		50	12.5	-15.3	15.4	-18.9	18.6	-22.9	22.2	-27.2	26.0	-32.0	30.2	-37.1	34.6	-42.5	44.5	-54.6
		100	12.1	-14.6	14.9	-18.0	18.1	-21.8	21.5	-25.9	25.2	-30.4	29.3	-35.3	33.6	-40.5	43.2	-52.0
	3	10	13.3	-17.0	16.5	-21.0	19.9	-25.5	23.7	-30.3	27.8	-35.6	32.3	-41.2	37.0	-47.3	47.6	-60.8
		20	13.0	-16.3	16.0	-20.1	19.4	-24.3	23.0	-29.0	27.0	-34.0	31.4	-39.4	36.0	-45.3	46.3	-58.1
		50	12.5	-15.3	15.4	-18.9	18.6	-22.9	22.2	-27.2	26.0	-32.0	30.2	-37.1	34.6	-42.5	44.5	-54.6
		100	12.1	-14.6	14.9	-18.0	18.1	-21.8	21.5	-25.9	25.2	-30.4	29.3	-35.3	33.6	-40.5	43.2	-52.0
Wall	4	10	14.6	-15.8	18.0	-19.5	21.8	-23.6	25.9	-28.1	30.4	-33.0	35.3	-38.2	40.5	-43.9	52.0	-56.4
		20	13.9	-15.1	17.2	-18.7	20.8	-22.6	24.7	-26.9	29.0	-31.6	33.7	-36.7	38.7	-42.1	49.6	-54.1
		50	13.0	-14.3	16.1	-17.6	19.5	-21.3	23.2	-25.4	27.2	-29.8	31.6	-34.6	36.2	-39.7	46.6	-51.0
		100	12.4	-13.6	15.3	-16.8	18.5	-20.4	22.0	-24.2	25.9	-28.4	30.0	-33.0	34.4	-37.8	44.2	-48.6
	5	10	14.6	-19.5	18.0	-24.1	21.8	-29.1	25.9	-34.7	30.4	-40.7	35.3	-47.2	40.5	-54.2	52.0	-69.6
		20	13.9	-18.2	17.2	-22.5	20.8	-27.2	24.7	-32.4	29.0	-38.0	33.7	-44.0	38.7	-50.5	49.6	-64.9
		50	13.0	-16.5	16.1	-20.3	19.5	-24.6	23.2	-29.3	27.2	-34.3	31.6	-39.8	36.2	-45.7	46.6	-58.7
		100	12.4	-15.1	15.3	-18.7	18.5	-22.6	22.0	-26.9	25.9	-31.6	30.0	-36.7	34.4	-42.1	44.2	-54.1
	5	500	10.9	-12.1	13.4	-14.9	16.2	-18.1	19.3	-21.5	22.7	-25.2	26.3	-29.3	30.2	-33.6	38.8	-43.2
		10	14.6	-19.5	18.0	-24.1	21.8	-29.1	25.9	-34.7	30.4	-40.7	35.3	-47.2	40.5	-54.2	52.0	-69.6
		20	13.9	-18.2	17.2	-22.5	20.8	-27.2	24.7	-32.4	29.0	-38.0	33.7	-44.0	38.7	-50.5	49.6	-64.9
		50	13.0	-16.5	16.1	-20.3	19.5	-24.6	23.2	-29.3	27.2	-34.3	31.6	-39.8	36.2	-45.7	46.6	-58.7
5	100	12.4	-15.1	15.3	-18.7	18.5	-22.6	22.0	-26.9	25.9	-31.6	30.0	-36.7	34.4	-42.1	44.2	-54.1	
	500	10.9	-12.1	13.4	-14.9	16.2	-18.1	19.3	-21.5	22.7	-25.2	26.3	-29.3	30.2	-33.6	38.8	-43.2	

Source: ASCE/SEI 7-05, Minimum Design Loads for Buildings and Other Structures, Chapter 6, Figure 6-3, p. 42-43.

Table 3.  $p_{net30}$  (psf) Roof Overhang

	Zone	Effective Wind Area (sf)	Basic Wind Speed, V (mph)							
			90	100	110	120	130	140	150	170
Roof 0 to 7 degrees	2	10	-21.0	-25.9	-31.4	-37.3	-43.8	-50.8	-58.3	-74.9
	2	20	-20.6	-25.5	-30.8	-36.7	-43.0	-49.9	-57.3	-73.6
	2	50	-20.1	-24.9	-30.1	-35.8	-42.0	-48.7	-55.9	-71.8
	2	100	-19.8	-24.4	-29.5	-35.1	-41.2	-47.8	-54.9	-70.5
	3	10	-34.6	-42.7	-51.6	-61.5	-72.1	-83.7	-96.0	-123.4
	3	20	-27.1	-33.5	-40.5	-48.3	-56.6	-65.7	-75.4	-96.8
	3	50	-17.3	-21.4	-25.9	-30.8	-36.1	-41.9	-48.1	-61.8
	3	100	-10.0	-12.2	-14.8	-17.6	-20.6	-23.9	-27.4	-35.2
Roof 7 to 27 degrees	2	10	-27.2	-33.5	-40.6	-48.3	-56.7	-65.7	-75.5	-96.9
	2	20	-27.2	-33.5	-40.6	-48.3	-56.7	-65.7	-75.5	-96.9
	2	50	-27.2	-33.5	-40.6	-48.3	-56.7	-65.7	-75.5	-96.9
	2	100	-27.2	-33.5	-40.6	-48.3	-56.7	-65.7	-75.5	-96.9
	3	10	-45.7	-56.4	-68.3	-81.2	-95.3	-110.6	-126.9	-163.0
	3	20	-41.2	-50.9	-61.6	-73.3	-86.0	-99.8	-114.5	-147.1
	3	50	-35.3	-43.6	-52.8	-62.8	-73.7	-85.5	-98.1	-126.1
	3	100	-30.9	-38.1	-46.1	-54.9	-64.4	-74.7	-85.8	-110.1
Roof 27 to 45 degrees	2	10	-24.7	-30.5	-36.9	-43.9	-51.5	-59.8	-68.6	-88.1
	2	20	-24.0	-29.6	-35.8	-42.6	-50.0	-58.0	-66.5	-85.5
	2	50	-23.0	-28.4	-34.3	-40.8	-47.9	-55.6	-63.8	-82.0
	2	100	-22.2	-27.4	-33.2	-39.5	-46.4	-53.8	-61.7	-79.3
	3	10	-24.7	-30.5	-36.9	-43.9	-51.5	-59.8	-68.6	-88.1
	3	20	-24.0	-29.6	-35.8	-42.6	-50.0	-58.0	-66.5	-85.5
	3	50	-23.0	-28.4	-34.3	-40.8	-47.9	-55.6	-63.8	-82.0
	3	100	-22.2	-27.4	-33.2	-39.5	-46.4	-53.8	-61.7	-79.3

Source: ASCE/SEI 7-05, Minimum Design Loads for Buildings and Other Structures, Chapter 6, p. 44.

**Step 5: Determine the Topographic Factor,  $K_{zt}$ :**

For the purposes of this code compliance document, the Topographic Factor,  $K_{zt}$ , is taken as equal to one (1), meaning, the installation is on level ground (less than 10% slope). If the installation is not on level ground, please consult ASCE 7-05, Section 6.5.7 and the local building authority to determine the Topographic Factor.

**EXPOSURE C** has open terrain with scattered obstructions having heights generally less than 30 feet. This category includes flat open country, grasslands, and all water surfaces in hurricane prone regions.

**EXPOSURE D** has flat, unobstructed areas and water surfaces outside hurricane prone regions. This category includes smooth mud flats, salt flats, and unbroken ice.

**Step 6: Determine Exposure Category (B, C, D):**

Determine the Exposure Category by using the following definitions for Exposure Categories.

Also see ASCE 7-05 pages 287-291 for further explanation and explanatory photographs, and confirm your selection with the local building authority.

The ASCE/SEI 7-05\* defines wind exposure categories as follows:

**EXPOSURE B** is urban and suburban areas, wooded areas, or other terrain with numerous closely spaced obstructions having the size of single family dwellings.

**Step 7: Determine adjustment factor for height and exposure category,  $\lambda$ :**

Using the *Exposure Category* (Step 6) and the *roof height, h (ft)*, look up the *adjustment factor for height and exposure* in Table 4.

**Step 8: Determine the Importance Factor, I:**

Determine if the installation is in a hurricane prone region. Look up the *Importance Factor, I*, Table 6, page 9, using the occupancy category description and the hurricane prone region status.

**Step 9: Calculate the Design Wind Load,  $p_{net}$  (psf):**

Multiply the *Net Design Wind Pressure,  $p_{net30}$  (psf)* (Step 4) by the *adjustment factor for height and exposure,  $\lambda$*  (Step 7), the *Topographic Factor,  $K_{zt}$*  (Step 5), and the *Importance Factor, I* (Step 8) using the following equation:

$$p_{net} (psf) = \lambda K_{zt} I p_{net30}$$

$p_{net}$  (psf) = Design Wind Load (10 psf minimum)

$\lambda$  = adjustment factor for height and exposure category (Step 7)

$K_{zt}$  = Topographic Factor at mean roof height, h (ft) (Step 5)

I = Importance Factor (Step 8)

$p_{net30}$  (psf) = net design wind pressure for Exposure B, at height = 30, I = 1 (Step 4)

Use Table 5 below to calculate Design Wind Load.

The Design Wind Load will be used in Part II to select the appropriate SunFrame Series rail, rail span and foot spacing.

Table 4. Adjustment Factor ( $\lambda$ ) for Roof Height & Exposure Category

Mean roof height (ft)	Exposure		
	B	C	D
15	1.00	1.21	1.47
20	1.00	1.29	1.55
25	1.00	1.35	1.61
30	1.00	1.40	1.66
35	1.05	1.45	1.70
40	1.09	1.49	1.74
45	1.12	1.53	1.78
50	1.16	1.56	1.81
55	1.19	1.59	1.84
60	1.22	1.62	1.87

Source: ASCE/SEI 7-05, Minimum Design Loads for Buildings and Other Structures, Chapter 6, Figure 6-3, p. 44.

Table 5. Worksheet for Components and Cladding Wind Load Calculation: IBC 2006, ASCE 7-05

Variable Description	Symbol	Value	Unit	Step	Reference
Building Height	$h$		ft		
Building, Least Horizontal Dimension			ft		
Roof Pitch			degrees		
Exposure Category				6	
Basic Wind Speed	$V$		mph	1	Figure 1
Effective Roof Area			sf		
				2	
Roof Zone Setback Length	$a$		ft	3	Table 1
Roof Zone Location				3	Figure 2
Net Design Wind Pressure	$p_{net30}$		psf	4	Table 2, 3
Topographic Factor	$K_{zt}$	x		5	
Adjustment factor for height and exposure category	$\lambda$	x		7	Table 4
Importance Factor	$I$	x		8	Table 5
Total Design Wind Load	$p_{net}$		psf	9	

Table 6. Occupancy Category Importance Factor

Category	Category Description	Building Type Examples	Non-Hurricane Prone Regions and Hurricane Prone Regions with Basic Wind Speed, $V = 85-100$ mph, and Alaska	Hurricane Prone Regions with Basic Wind Speed, $V > 100$ mph
I	Buildings and other structures that represent a low hazard to human life in the event of failure, including, but limited to:	Agricultural facilities Certain Temporary facilities Minor Storage facilities	0.87	0.77
II	All buildings and other structures except those listed in Occupancy Categories I, III, and IV.		I	I
III	Buildings and other structures that represent a substantial hazard to human life in the event of a failure, including, but not limited to:	Buildings where more than 300 people congregate Schools with a capacity more than 250 Day Cares with a capacity more than 150 Buildings for colleges with a capacity more than 500 Health Care facilities with a capacity more than 50 or more resident patients Jails and Detention Facilities Power Generating Stations Water and Sewage Treatment Facilities Telecommunication Centers Buildings that manufacture or house hazardous materials	1.15	1.15
IV	Buildings and other structures designated as essential facilities, including, but not limited to:	Hospitals and other health care facilities having surgery or emergency treatment Fire, rescue, ambulance and police stations Designated earthquake, hurricane, or other emergency shelters Designated emergency preparedness communication, and operation centers Power generating stations and other public utility facilities required in an emergency Ancillary structures required for operation of Occupancy Category IV structures Aviation control towers, air traffic control centers, and emergency aircraft hangars Water storage facilities and pump structures required to maintain water pressure for fire suppression Buildings and other structures having critical national defense functions	1.15	1.15

Source: IBC 2006, Table 1604.5, Occupancy Category of Buildings and other structures, p. 281; ASCE/SEI 7-05, Minimum Design Loads for Buildings and Other Structures, Table 6-1, p. 77

## Part II. Procedure to Select Rail Span and Rail Type

### [2.1.] Using Standard Beam Calculations, Structural Engineering Methodology:

The procedure to determine the Unirac SunFrame series rail type and rail span uses standard beam calculations and structural engineering methodology. The beam calculations are based on a simply supported beam conservatively, ignoring the reductions allowed for supports of continuous beams over multiple supports. Please refer to **Part I** for more information on beam calculations, equations and assumptions.

**In using this document, obtaining correct results is dependent upon the following:**

1. Obtain the *Snow Load* for your area from your local building official.
2. Obtain the *Design Wind Load, p<sub>net</sub>*. See **Part I** (Procedure to Determine the Design Wind Load) for more information on calculating the *Design Wind Load*.
3. *Please Note:* The terms rail span and footing spacing are interchangeable in this document. See **Figure 3** for illustrations.
4. To use **Table 8a** and **Table 8b** the *Dead Load* for your specific installation must be less than 5 psf, including modules and Unirac racking systems. If the *Dead Load* is greater than 5 psf, see your Unirac distributor, a local structural engineer or contact Unirac.

The following procedure will guide you in selecting a Unirac rail for a flush mount installation. It will also help determine the design loading imposed by the Unirac PV Mounting Assembly that the building structure must be capable of supporting.

#### Step 1: Determine the Total Design Load:

The *Total Design Load, P (psf)* is determined using ASCE 7-05 2.4.1 (ASD Method equations 3,5,6 and 7) by adding the *Snow Load<sup>1</sup>, S (psf)*, *Design Wind Load, p<sub>net</sub> (psf)* from **Part I, Step 9** and the *Dead Load (psf)*. Both Uplift and Downforce Wind Loads calculated in **Step 9** of **Part 2** must be investigated. Use **Table 7** to calculate the Total Design Load for the load cases. The beam must be sized for uplift, downforce and side loads. Use the maximum absolute value of the three downforce cases and the uplift case to size the beam for uplift and downforce. Use the side load case to size the beam for side load. Use the uplift case only for sizing lag bolts pull out capacities (Part II, Step 6).

$$P \text{ (psf)} = 1.0D + 1.0S^1 \text{ (downforce case 1)}$$

$$P \text{ (psf)} = 1.0D + 1.0p_{net} \text{ (downforce case 2)}$$

$$P \text{ (psf)} = 1.0D + 0.75S^1 + 0.75p_{net} \text{ (downforce case 3)}$$

$$P \text{ (psf)} = 0.6D + 1.0p_{net} \text{ (uplift)}$$

$$P \text{ (psf)} = \sin(\text{roof angle})D + \sin(\text{roof angle})S \text{ (side)}$$

$$D = \text{Dead Load (psf)}$$

$$S = \text{Snow Load (psf)}$$

$$p_{net} = \text{Design Wind Load (psf)}$$

The maximum *Dead Load, D (psf)*, is 5 psf based on market research and internal data.

<sup>1</sup>*Snow Load Reduction* - The snow load can be reduced according to Chapter 7 of ASCE 7-05. The reduction is a function of the roof slope, Exposure Factor, Importance Factor and Thermal Factor. Please refer to Chapter 7 of ASCE 7-05 for more information.

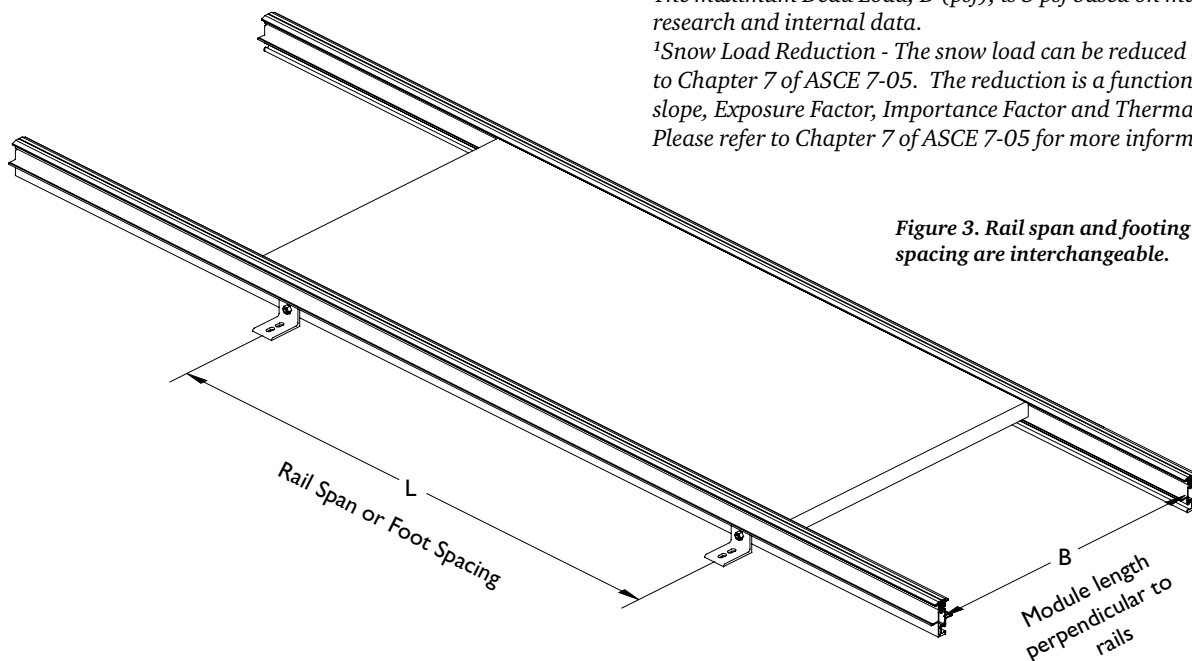

**Figure 3. Rail span and footing spacing are interchangeable.**

**Note:** Modules must be centered symmetrically on the rails (+/- 2\*), as shown in Figure 3. If this is not the case, call Unirac for assistance.

**Table 7. ASCE 7 ASD Load Combinations**

Description	Variable	Downforce Case 1	Downforce Case 2	Downforce Case 3	Uplift	Side	Units
Dead Load	D	1.0 x D _____	1.0 x D _____	1.0 x D _____	0.6 x D _____	sin(roof angle) x D _____	psf
Snow Load	S	1.0 x S _____		0.75 x S _____		sin(roof angle) x S _____	psf
Design Wind Load	P <sub>net</sub>		1.0 x P <sub>net</sub> _____	0.75 x P <sub>net</sub> _____	1.0 x P <sub>net</sub> _____		psf
Total Design Load P	P	Sum of above two numbers _____	Sum of above two numbers _____	Sum of above 3 numbers _____	Sum above two numbers* _____	Sum above two numbers _____	psf

Note: Table to be filled out or attached for evaluation.

\*Note: P<sub>net</sub> uplift will be a negative number

**Step 2a: Determine the Distributed Load on the rail based on uplift and downforce, w (plf):**

Determine the *Distributed Load, w (plf)*, by multiplying the module dimension, B (ft), by the *Total Design Load, P (psf)*. Use the maximum absolute value of the three downforce cases and the Uplift Case. We assume each module is supported by one rail.

$$w = PB$$

w = Distributed Load (pounds per linear foot, plf)

B = Module Dimension Perpendicular to Rails (ft., see Figure 3)

P = Total Design Pressure (pounds per square foot, psf)

**Step 2b: Determine the Distributed Load on the rail based on side load, w (plf):**

Determine the *Distributed Load w (plf)*, by multiplying the module width B (ft) by the *Total Design Load P (side)*

$$w = PB$$

w = Distributed Load (pounds per linear foot, plf)

B = Module Dimension Perpendicular to Rails (ft)

P = Total Design Pressure for side load (pounds per square foot, psf)

**Step 3: Determine Rail Span/ L-Foot Spacing:**

Using the *distributed load, w*, from **Part II, Step 2**, look up the *allowable spans, L*, for SunFrame.

There are two tables, **Table 8a** for uplift and downforce and **Table 8b** for side load. Look up the allowable span for uplift/downforce from **Table 8a** and side load from **Table 8b**. Span for the system will be the lower of the 2 appropriate values from **Tables 8a and 8b**.

**Table 8a. L-Foot SunFrame Series Rail Span (uplift and downforce)**

Span (ft)	w = Distributed Load (plf)																	
	20	25	30	40	50	60	80	100	120	140	160	180	200	220	240	260	280	300
2	SF	SF	SF	SF	SF	SF	SF	SF	SF	SF	SF	SF	SF	SF	SF	SF	SF	SF
2.5	SF	SF	SF	SF	SF	SF	SF	SF	SF	SF	SF	SF	SF	SF	SF	SF	SF	SF
3	SF	SF	SF	SF	SF	SF	SF	SF	SF	SF	SF	SF	SF	SF	SF	SF	SF	SF
3.5	SF	SF	SF	SF	SF	SF	SF	SF	SF	SF	SF	SF	SF	SF	SF	SF	SF	SF
4	SF	SF	SF	SF	SF	SF	SF	SF	SF	SF	SF	SF	SF	SF	SF	SF	SF	SF
4.5	SF	SF	SF	SF	SF	SF	SF	SF	SF	SF	SF	SF	SF	SF	SF	SF	SF	SF
5	SF	SF	SF	SF	SF	SF	SF	SF	SF	SF	SF	SF	SF	SF	SF	SF	SF	SF
5.5	SF	SF	SF	SF	SF	SF	SF	SF	SF	SF	SF	SF	SF	SF	SF	SF	SF	SF
6	SF	SF	SF	SF	SF	SF	SF	SF	SF	SF	SF	SF	SF	SF	SF	SF	SF	SF
6.5	SF	SF	SF	SF	SF	SF	SF	SF	SF	SF	SF	SF	SF	SF	SF	SF	SF	SF
7	SF	SF	SF	SF	SF	SF	SF	SF	SF	SF	SF	SF	SF	SF	SF	SF	SF	SF
7.5	SF	SF	SF	SF	SF	SF	SF	SF	SF	SF	SF	SF	SF	SF	SF	SF	SF	SF
8	SF	SF	SF	SF	SF	SF	SF	SF	SF	SF	SF	SF	SF	SF	SF	SF	SF	SF
8.5	SF	SF	SF	SF	SF	SF	SF	SF	SF	SF	SF	SF	SF	SF	SF	SF	SF	SF
9	SF	SF	SF	SF	SF	SF	SF	SF	SF	SF	SF	SF	SF	SF	SF	SF	SF	SF
9.5	SF	SF	SF	SF	SF	SF	SF	SF	SF	SF	SF	SF	SF	SF	SF	SF	SF	SF
10	SF	SF	SF	SF	SF	SF	SF	SF	SF	SF	SF	SF	SF	SF	SF	SF	SF	SF
10.5	SF	SF	SF	SF	SF	SF	SF	SF	SF	SF	SF	SF	SF	SF	SF	SF	SF	SF
11	SF	SF	SF	SF	SF	SF	SF	SF	SF	SF	SF	SF	SF	SF	SF	SF	SF	SF
11.5	SF	SF	SF	SF	SF	SF	SF	SF	SF	SF	SF	SF	SF	SF	SF	SF	SF	SF
12	SF	SF	SF	SF	SF	SF	SF	SF	SF	SF	SF	SF	SF	SF	SF	SF	SF	SF

Table 8b. L-Foot SunFrame Series Rail Span (side load)

Span (ft)	= Distributed Load (plf)																	
	5	10	15	20	25	30	35	40	45	50	55	60	65	70	75	80	85	90
2	SF	SF	SF	SF	SF	SF	SF	SF	SF	SF	SF	SF	SF	SF	SF	SF	SF	SF
2.5	SF	SF	SF	SF	SF	SF	SF	SF	SF	SF	SF	SF	SF	SF	SF			
3	SF	SF	SF	SF	SF	SF	SF	SF	SF	SF	SF	SF	SF	SF				
3.5	SF	SF	SF	SF	SF	SF	SF	SF	SF	SF								
4	SF	SF	SF	SF	SF	SF	SF	SF	SF									
4.5	SF	SF	SF	SF	SF	SF	SF	SF	SF									
5	SF	SF	SF	SF	SF	SF	SF	SF										
5.5	SF	SF	SF	SF	SF	SF												
6	SF	SF	SF	SF	SF	SF												
6.5	SF	SF	SF	SF	SF													
7	SF	SF	SF	SF														
7.5	SF	SF	SF	SF														
8	SF	SF	SF															
8.5	SF	SF	SF															
9	SF	SF																
9.5	SF	SF																
10	SF	SF																
10.5	SF																	
11	SF																	
11.5	SF																	
12	SF																	

**Step 4: Select Rail Type:**

Selecting a span affects the price of your installation. Longer spans produce fewer wall or roof penetrations. However, longer spans create higher point load forces on the building structure. A point load force is the amount of force transferred to the building structure at each connection.

**It is the installer’s responsibility to verify that the building structure is strong enough to support the point load forces.**

**Step 5: Determine the Downforce Point Load, R (lbs), at each connection based on rail span:**

When designing the Unirac Flush Mount Installation, you must consider the downforce Point Load, R (lbs) on the roof structure.

The Downforce, Point Load, R (lbs), is determined by multiplying the Total Design Load, P (psf) (Step 1) by the Rail Span, L (ft) (Step 3) and the Module Length Perpendicular to the Rails, B (ft).

$$R \text{ (lbs)} = PLB$$

R = Point Load (lbs)

P = Total Design Load (psf)

L = Rail Span (ft)

B = Module Length Perpendicular to Rails (ft)

It is the installer’s responsibility to verify that the building structure is strong enough to support the maximum point loads calculated according to Step 5.

**Table 9. Downforce Point Load Calculation**

Total Design Load (downforce) (max of case 1, 2 or 3)	P		psf	Step 1
Module length perpendicular to rails	B	x	ft	
Rail Span	L	x _____	ft	Step 4
Downforce Point Load	R		lbs	

**Step 6: Determine the Uplift Point Load, R (lbs), at each connection based on rail span:**

You must also consider the Uplift Point Load, R (lbs), to determine the required lag bolt attachment to the roof (building) structure.

**Table 10. Uplift Point Load Calculation**

Total Design Load (uplift)	P		psf	Step 1
Module length perpendicular to rails	B	x	ft	
Rail Span	L	x _____	ft	Step 4
Uplift Point Load	R		lbs	

**Table 11. Lag pull-out (withdrawal) capacities (lbs) in typical roof lumber (ASD)**

	Specific gravity	Lag screw specifications
		<sup>5</sup> / <sub>16</sub> " shaft,* per inch thread depth
<b>Douglas Fir, Larch</b>	<b>0.50</b>	<b>266</b>
<b>Douglas Fir, South</b>	<b>0.46</b>	<b>235</b>
<b>Engelmann Spruce, Lodgepole Pine (MSR 1650 f &amp; higher)</b>	<b>0.46</b>	<b>235</b>
<b>Hem, Fir, Redwood (close grain)</b>	<b>0.43</b>	<b>212</b>
<b>Hem, Fir (North)</b>	<b>0.46</b>	<b>235</b>
<b>Southern Pine</b>	<b>0.55</b>	<b>307</b>
<b>Spruce, Pine, Fir</b>	<b>0.42</b>	<b>205</b>
<b>Spruce, Pine, Fir (E of 2 million psi and higher grades of MSR and MEL)</b>	<b>0.50</b>	<b>266</b>

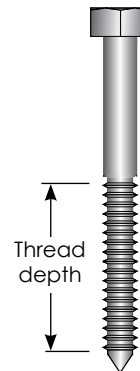

Use **Table 11** to select a lag bolt size and embedment depth to satisfy your Uplift Point Load Force, R (lbs), requirements.

It is the installer’s responsibility to verify that the substructure and attachment method is strong enough to support the maximum point loads calculated according to **Step 5** and **Step 6**.

Sources: American Wood Council, NDS 2005, Table 11.2A, 11.3.2A.

- Notes: (1) Thread must be embedded in the side grain of a rafter or other structural member integral with the building structure.  
 (2) Lag bolts must be located in the middle third of the structural member.  
 (3) These values are not valid for wet service.  
 (4) This table does not include shear capacities. If necessary, contact a local engineer to specify lag bolt size with regard to shear forces.  
 (5) Install lag bolts with head and washer flush to surface (no gap). Do not over-torque.  
 (6) Withdrawal design values for lag screw connections shall be multiplied by applicable adjustment factors if necessary. See Table 10.3.1 in the American Wood Council NDS for Wood Construction.

\*Use flat washers with lag screws.

## Part III. Installing SunFrame

The Unirac Code-Compliant Installation Instructions supports applications for building permits for photovoltaic arrays using Unirac PV module mounting systems.

This manual, SunFrame Rail Planning and Assembly, governs installations using the SunFrame systems.

### [3.1.] SunFrame<sup>®</sup> rail components:

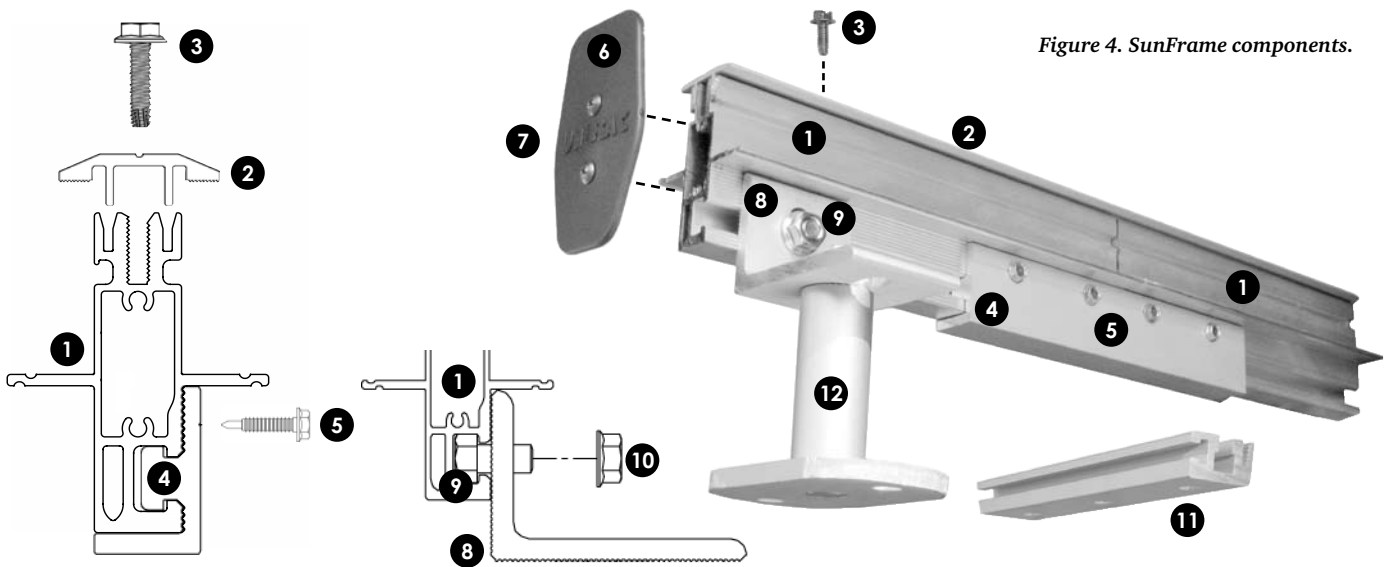

Figure 4. SunFrame components.

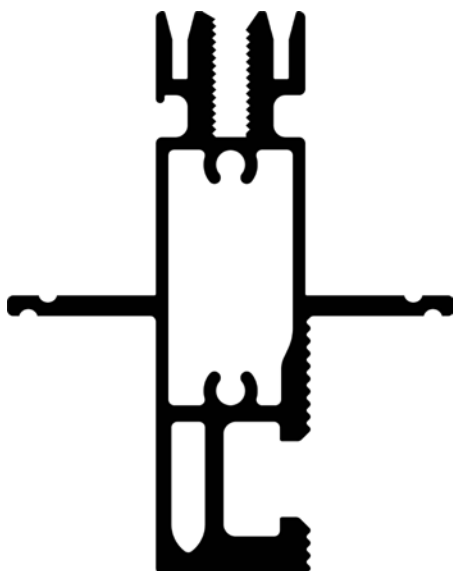

Figure 5. SunFrame threaded slot rail, cross section, actual size.

- 1 **Rail**— Supports PV modules. Use one per row of modules plus one. Shipped in 8- or 16-foot lengths. Aluminum extrusion, anodized (clear or dark bronze) to match PV module frame.
  - 2 **Cap strip**— Secures PV modules to rails and neatly frames top of array. Lengths equals rail lengths. Cap strips are sized for specific PV modules. Shipped in 8- or 16-foot lengths. Predrilled every 8 inches. Aluminum extrusion, anodized (clear or dark bronze) to match PV module frame.
  - 3 **Cap strip screw** (1/4-20 x 1, Type F thread cutting)— Use to secure each cap strip (and PV modules) to rail, one per predrilled hole. Use an additional end screw wherever a predrilled hole does not fall within 4 inches of the end of any cap strip segment. 18-8 stainless steel, clear or black to match cap strip.
  - 4 **Rail splice**— Joins rail sections into single length of rail. It can form either a rigid or thermal expansion joint. 8 inches long, predrilled. Aluminum extrusion, anodized (clear or dark bronze) to match PV module frame.
  - 5 **Self-drilling screw** (No. 10 x 3/4")— Use 4 per rigid splice or 2 per expansion joint. Stainless steel.
  - 6 **End caps**— Use one to neatly close each rail end. UV resistant black plastic.
  - 7 **Truss-head sheet metal screw** (No. 8 x 5/8")— Use 2 per end cap to secure end cap to rail. 18-8 stainless steel; with black zinc chromate coating to match end caps.
  - 8 **L-foot**— Use to secure rails either through roofing material to rafters, to L-foot adjusting sliders, or to standoffs. Use no less than one L-foot per 4 feet of rail. Aluminum extrusion, anodized (clear or dark bronze) to match PV module frame.
  - 9 **L-foot bolt** (3/8" x 3/4")— Use one per L-foot to secure rail to L-foot. Stainless steel.
  - 10 **Flange nut** (3/8")— Use one per L-foot bolt. 304 stainless steel.
  - 11 **L-foot adjusting slider** (optional)— Use one beneath each L-foot or aluminum two-piece standoff, except in lowest row. Aluminum extrusion. Sliders allow easier alignment of rails and better snugging of PV modules between rails. Includes 3/8" x 1-1/4" bolt with flange nut for attaching L-foot or standoff shaft, and two 5/16" x 2-1/2" lag bolts with flat washers for securing sliders to rafters.
  - 12 **Two-piece** (pictured)— Aluminum extrusion. Includes 3/8" x 3/4" serrated flange bolt with EPDM washer for attaching L-foot, and two 5/16" x 3-1/2" lag bolts.
- Flattop standoff** (optional)— Use if L-foot cannot be secured directly to rafter (with tile or shake roofs, for example). Use one per L-foot.
- One-piece**— Service Condition 4 (very severe) zinc-plated welded steel. Includes 3/8" x 3/4" bolt with lock washer for attaching L-foot.
- Flashings**— Use one per standoff. Unirac offers appropriate flashings for both standoff types.

#### Installer supplied materials:

**Lag screw for L-foot**— Attaches L-foot or standoff to rafter. Determine length and diameter based on pull-out values in **Table 3 (page 13)**. If lag screw head is exposed to elements, use stainless steel. Under flashings, zinc plated hardware is adequate. *Note: Lag screws are provided with L-foot adjusting sliders and standoffs.*

**Waterproof roofing sealant**— Use a sealant appropriate to your roofing material.

**Clamps for standing seam metal roof**— See "Frequently Asked Questions . . ." (p. 23).



*Stainless steel hardware can seize up, a process called galling. To significantly reduce its likelihood, (1) apply lubricant to bolts, preferably an anti-seize lubricant, available at auto parts stores, (2) shade hardware prior to installation, and (3) avoid spinning on nuts at high speed. See Installation Supplement 910, Galling and Its Prevention, at [www.unirac.com](http://www.unirac.com).*

## Installing the array:

Safe, efficient SunFrame installation involves three principal tasks:

- A. Laying out the installation area and planning for material conservation.
- B. Installing footings and rails, beginning with the *lowest* row and moving up the roof.
- C. Placing modules and cap strips, beginning with the *highest* row and moving down the roof.

The following illustrated steps describe the procedure in detail. Before beginning, please note these important considerations.



- **Footings must be lagged into structural members. Never attach them to the decking alone, which leaves both the array and roof susceptible to severe damage.**
- **A thermal break is required every 40 feet of continuously connected rail. See Unirac Splices and Expansion Joints Installation Manual for details.**
- **There is no UGC (Unirac Grounding Clip) available for SunFrame.**

**Sample layout, illustrated in Figure 6**

Assumptions: 12 modules (60" x 36"),  
arranged in 3 rows of 4 modules

**Array width** = 144" (36" module width x 4 modules per row)

**Array length** = 180" (60" module length x 3 rows)  
+ 3" (1½" end rail width x 2 rails)  
+ 1½" (¾" between-module rail width x 2 rails)  
= 184½"

### 1. Laying out the installation area:

Always install SunFrame rails perpendicular to rafters. (These instructions assume typical rafters that run from the gutter to the peak of the roof. If this is not the case, contact Unirac.) Rails are typically mounted horizontally (parallel to the lower edge of the roof), and *must* be mounted within 10 degrees of horizontal.

Leave adequate room to move safely around the array during installation. During module installation, you will need to slide one module in each row about a foot beyond the end of the rails on one side. Using the number of rows and the number of modules per row in your installation, determine the size of your array area following Figure 6.

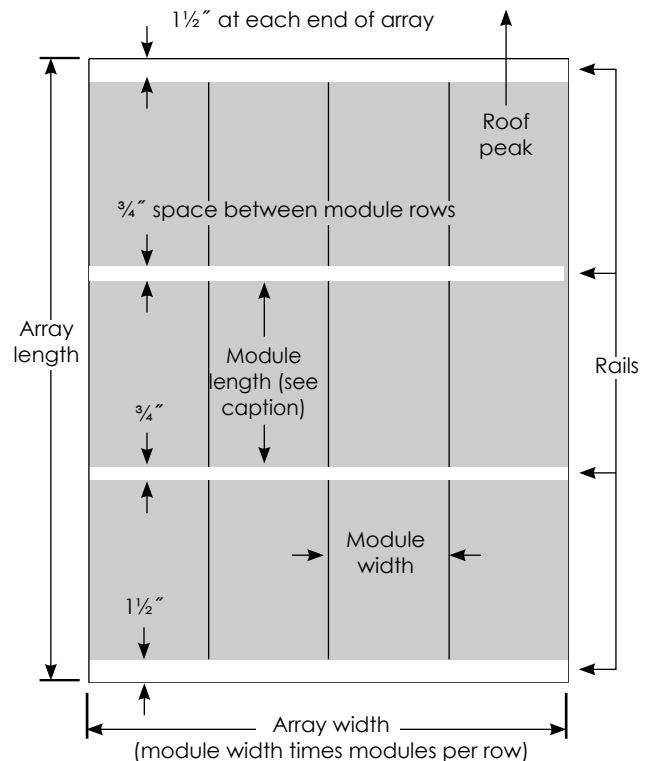

**Figure 6. Installation area layout. Note: Module length is not necessarily measured from the edges of the frame. Some frames have lips. Others are assembled with pan-head screws. All such features must be included in module length.**

## 2. Installing the lowest row of L-feet and rail:

In the lowest row, it is not necessary to use L-foot adjusting sliders, even if you plan to use them in subsequent rows. Install L-foot directly onto low profile roofing material such as asphalt shingles or sheet metal. (For high profile roofs, such as tile or shake, use optional standoffs with flashing to raise L-foot. L-foot must be flush with or above the highest point of the roof surface.)

L-feet can be placed with the double-slotted side against the roof surface (as in **Fig. 7**) or with the single-slotted side against the roof (which increases air circulation beneath modules). Module-to-roof dimensions are listed on page 19 for both arrangements.



**If you are using L-foot adjusting sliders, you must use the short side of the the L-foot against the roof in the first row. See Figure 9 below.**

**If you are using both L-foot adjusting sliders and standoffs, see the upper box on page 18.**

Install the first row of L-feet at the lower edge of the installation area (**Fig. 8**). Ensure feet are aligned by using a chalk line. (A SunFrame rail can also be used as a straight edge.) Position the L-feet with respect to the lower edge of the roof as illustrated in Figures 7 and 8.

Drill a pilot hole through roof into the center of the rafter at each L-foot lag screw hole location. Apply weatherproof sealant into the hole and onto shafts of the lag screws. Seal the underside of the L-feet with a suitable weatherproof sealant.

Fasten the L-feet to the roof with the lag screws. **If the double slotted sides of the L-foot are against the roof, lag through the slot nearest the bend in the L-foot (Figs. 7 and 8).**

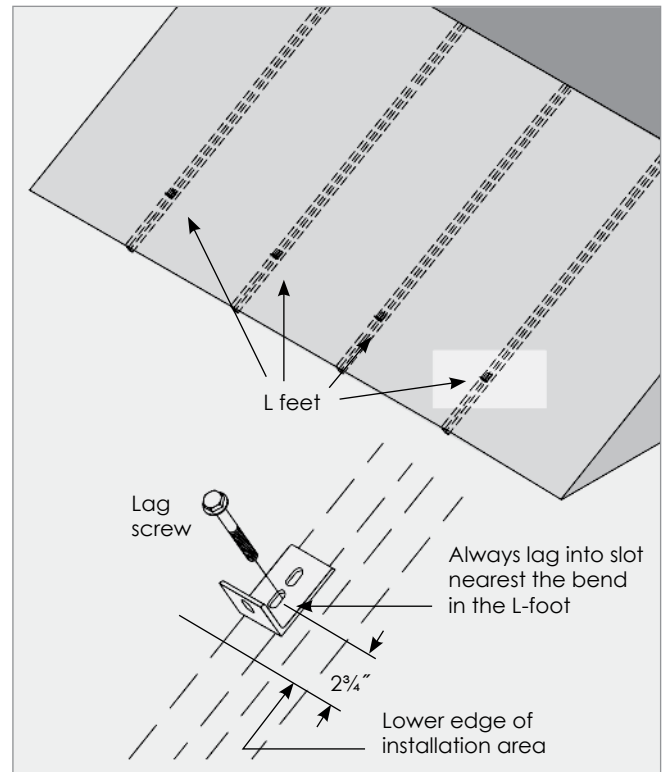
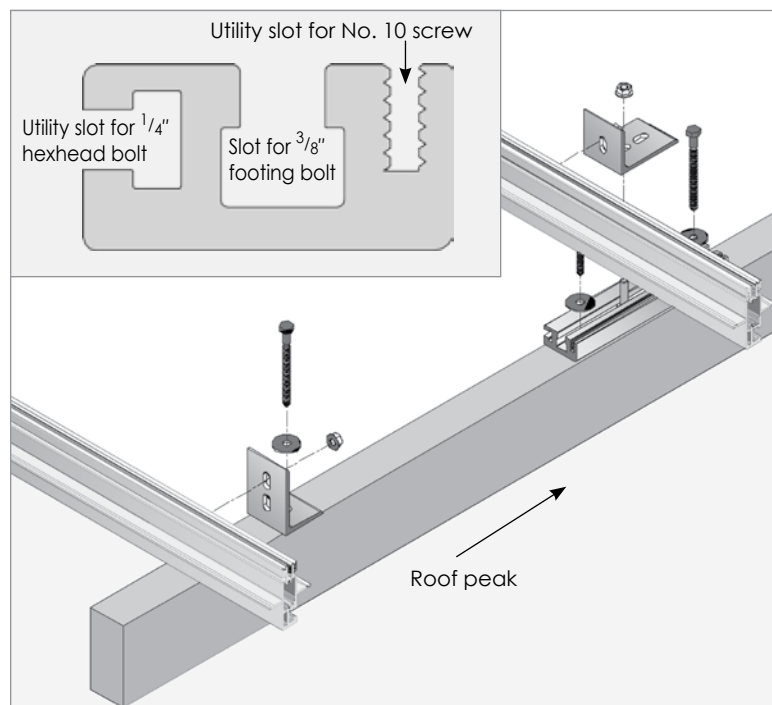

**Figure 7. Placement of first L-foot row.**

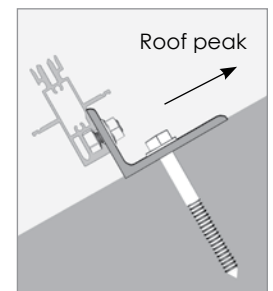

**Figure 8. L-Foot orientation.**

Cut the rails to your array width, being sure to keep rail slots free of roofing grit or other debris. If your installation requires splices, assemble them prior to attaching L-feet (see “Footing and splicing requirements,” **p. 18**, and “Material planning for rails and cap strips,” **p. 20**). Slide the  $\frac{3}{8}$ -inch mounting bolts into the footing slots. *If more than one splice is used on a rail, slide L-foot bolt(s) into the footing slot(s) of the interior rail segment(s) before splicing.*

Loosely attach the rails to the L-feet with the flange nuts. Ensure that rails are oriented with respect to the L-feet as shown in **Figure 9**. Align the ends of the rail to the edge of the installation area. Ensure that the rail is straight and parallel to the edge of the roof. Then tighten the lag screws.

**Figure 9. L-foot orientation in conjunction with L-foot adjusting sliders. The sliders include two utility slots to secure module wiring, combiner boxes, and other system components.**

## Using standoffs with L-foot adjusting sliders

Two-piece aluminum standoffs may be used with footing sliders, although flashings may not be available to cover the entire length of the slider. Use the bases of the standoffs only in the lowest row. In subsequent rows, attach the shaft

of each standoff to the slider using the slider's  $\frac{3}{8}$ -inch hex-head bolt. Note that L-feet are positioned long side up on the lowest rows and with long side down in subsequent rows—in the same manner as an installation with no standoffs.

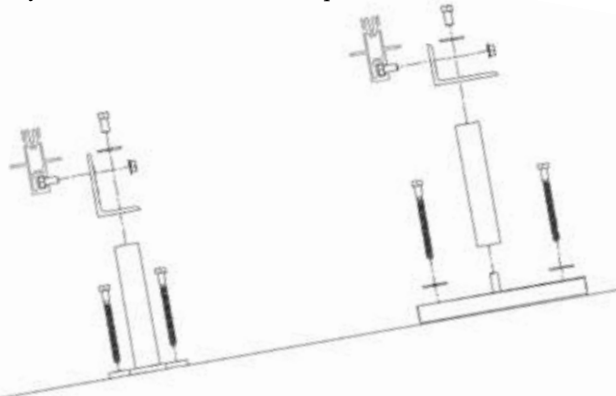

With standoffs of equal length, orient L-foot to compensate for height difference.

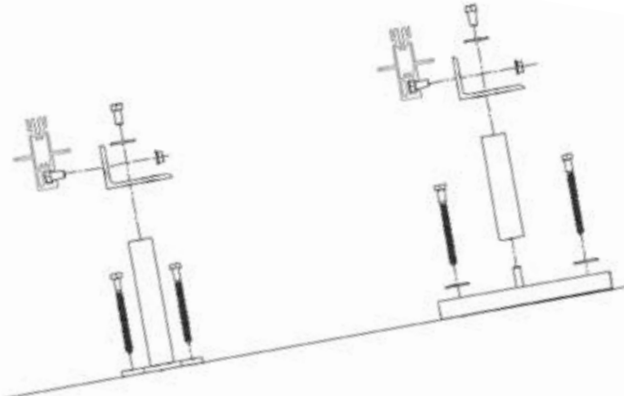

If the standoff supporting the lowest rail is 1 inch taller than the standoffs on the footing sliders, place both L-feet in the same orientation—either both long side up or both short side up.



This example assumes a rail seven times the length of the footing spacing (A). A splice may be located in any of the

shaded areas. If more than one splice is used, be sure the combination does not violate the following requirements:

## Footing and splicing requirements

The following criteria are required for sound installations.

While short sections of rail are structurally permissible, they can usually be avoided by effective planning, which also promotes superior aesthetics. See “Material planning for rails and cap strips” (p. 20).

*The installer is solely responsible for ensuring that the roof and its structural members can support the array and its live loads.*

*A thermal break is required every 40 feet of continuously connected rail. See Unirac Splices and Expansion Joints Installation Manual for details.*

1. Footing spacing along the rail (A in illustration above) is determined by wind loading (see pp. 2–3, especially step 1). Foot spacing at 48 inches is advised.
2. Overhang (B) must be no more than half the length of the maximum footing spacing (A). For example, if Span A is 32 inches, Overhang B should not exceed 16 inches.

3. Do not locate a splice in the center third of the span between two adjacent feet.
4. In a spliced length of rail, all sections must be supported by no less than two L-feet.
5. Rail sections longer than half the footing spacing require no fewer than two L-feet.

*Modules should always be fully supported by rails. In other words, modules should never overhang rails. This is especially critical when supporting the short side of a non-rectangular module. When a rail supports a pair of non-rectangular modules by themselves (right), it must be supported by at least two L-feet. The rail should be at least 14 and no more than 24 inches long, which will likely require a stringer between rafters to ensure proper footings.*

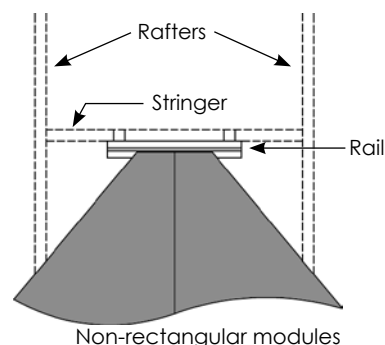

### 3. Laying out and installing the next row of L-feet:

**With L-feet only:** Position the second row of L-feet in accordance with **Figure 10**. Ensure that you measure between the lower bolt hole centers of each row of L-foot. Install the second row of L-feet in the same manner and orientation as the first row, but leave the lag screws a half turn loose. Be aware of the set-up time of your sealant; the L-feet will not be fully tightened until **Step 4**.

**With L-foot adjusting sliders:** Use a chalk line to mark the position of the slider center holes of the next row. The illustration below provides spacing guidelines. The length of the module (A in **Fig. 11**) includes any protrusions, such as lips or pan-head screws in its frame.

Attach and seal L-foot adjusting slider: Install lower lag first, *footing bolt next*, and upper lag last. Attach an L-foot with its short side up to each slider.

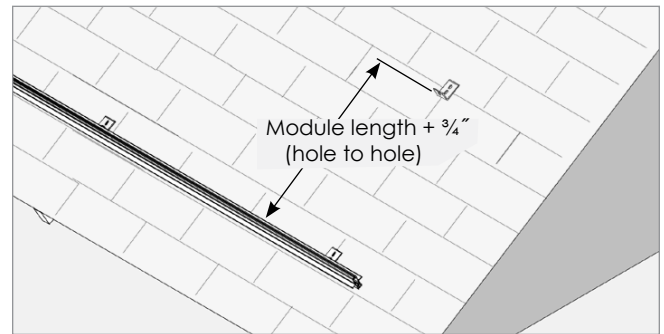

**Figure 10.** L-foot separation. See the note on module length in the caption of **Figure 3** (p. 10).

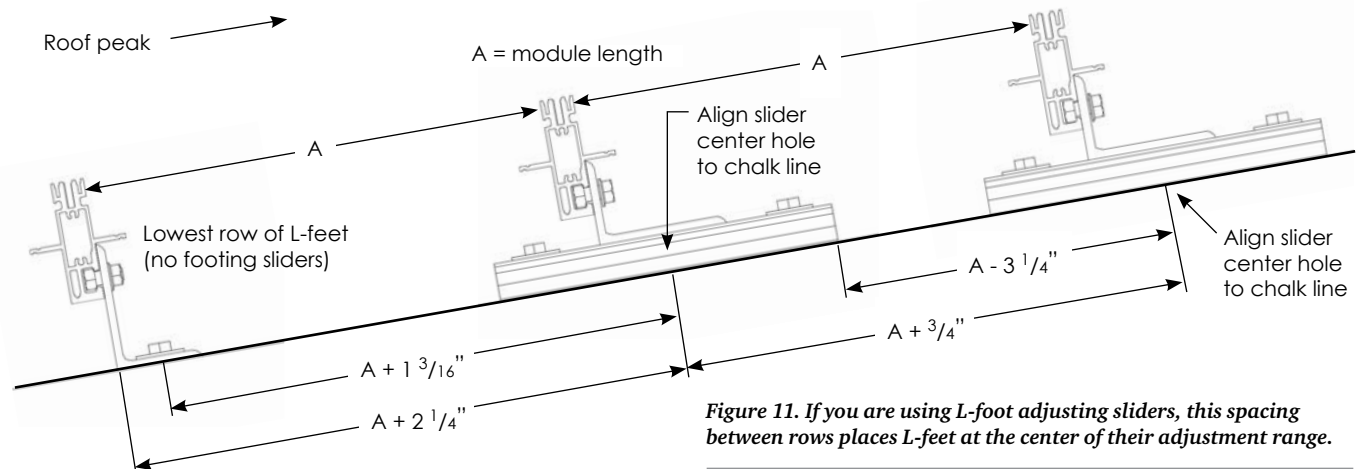

**Figure 11.** If you are using L-foot adjusting sliders, this spacing between rows places L-feet at the center of their adjustment range.

### 4. Installing the second rail:

**With L-feet only (Fig. 12):** Install and align the second rail in the same manner and orientation as the first rail. After rail alignment, tighten the rail mounting bolts.

Lay one module in place at one end of the rails, and snug the upper rail (**Fig. 12**) toward the lower rail, leaving no gap between the ends of the modules and either rail. (If pan-head screw heads represent the true end of the modules, be sure the screw heads touch the rails on both ends.) Tighten the lag screw on that end. Slide the module down the rails, snugging the rails and tightening the remaining lag screws as you go.

**With L-foot adjusting sliders:** Install rails on first and second rows of L-feet. Verify spacing by placing a module onto the rails at several points along the row. Adjust L-foot positions as needed.

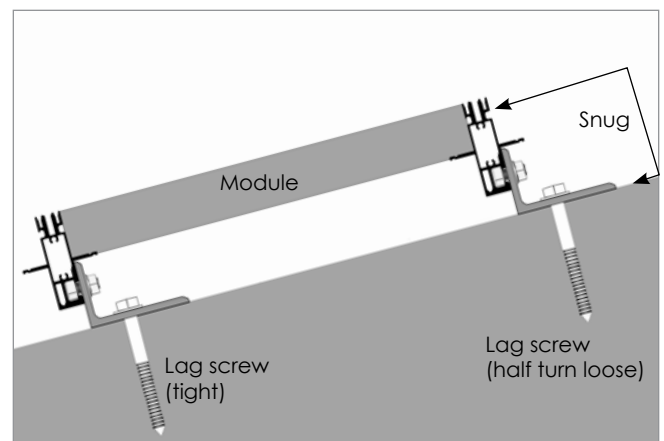

**Figure 12.** Position and secure top rail.

### 5. Installing remaining L-feet and rails:

Install the L-feet and the rails for the remaining rows, following **Steps 3 and 4**. You may use the same module to space all the rows. When complete, confirm that:

- All rails are fitted and aligned.
- All footing bolts and lag screws are secure.
- The module used for fitting is resting (but not secured) in the highest row.

## Material planning for rails and cap strips

Preplanning material use for your particular array can prevent structural or aesthetic problems, particularly those caused by very short lengths of rail or cap strip. This example illustrates one approach.

Structural requirements for rails are detailed in “Footing and splicing requirements” (p.18). Structurally, cap strips require:

- A screw in every prepunched hole (which occur every 8 inches, beginning 4 inches from the ends of the rails).
- One screw 4 inches or less from the each end of every rail segment. Wherever there is no prepunched hole within 4 inches of an end of a segment, drill a 1/4-inch hole 2 inches from the end of the segment and install a cap strip screw. (In most cases, you can avoid this situation with good material planning.)

Structural requirements always take precedence, but usually good planning can also achieve both material conservation and superior aesthetics. This example conserves material and achieves two specific aesthetic goals:

- Cap strip screws must align across the rails.
- End screws must be equidistant from both sides of the array.

The example assumes an array of three rows, each holding five modules 41 inches wide. Thus, four 205-inch rail

assemblies and cap strip assemblies need to be cut and spliced from 192-inch sections of rail and cap strip. The example illustrates one means of doing so, without violating structural requirements or aesthetic goals.

Rail segments come from five 192-inch lengths, lettered A thru E. Rail A, for example, is cut into two 96-inch segments, with one segment spliced into each of the first two rails. Similarly, five 192-inch cap strips are designated V through Z.

All cap strip segments are cut at the midpoint between prepunched screw holes. For each rail, start with the cap strip segment that crosses the array center line, and position over the center line so that the appropriate holes are spaced equally on either side.

Position each cap strip onto its rail and mark its trim point. Remove and trim before final mounting.

**Preliminary footing and splice positions must be checked against structural requirements in “Footing and splicing requirements” (p.18). In this example, the center of the array is offset 2 inches from the center rafter. This prevents rail splices BD (3rd rail) and CE (4th rail) from falling too close to the center of the spans between footings (Requirement 3, p. 18). Because footings are not visible from ground level, there is negligible aesthetic loss.**

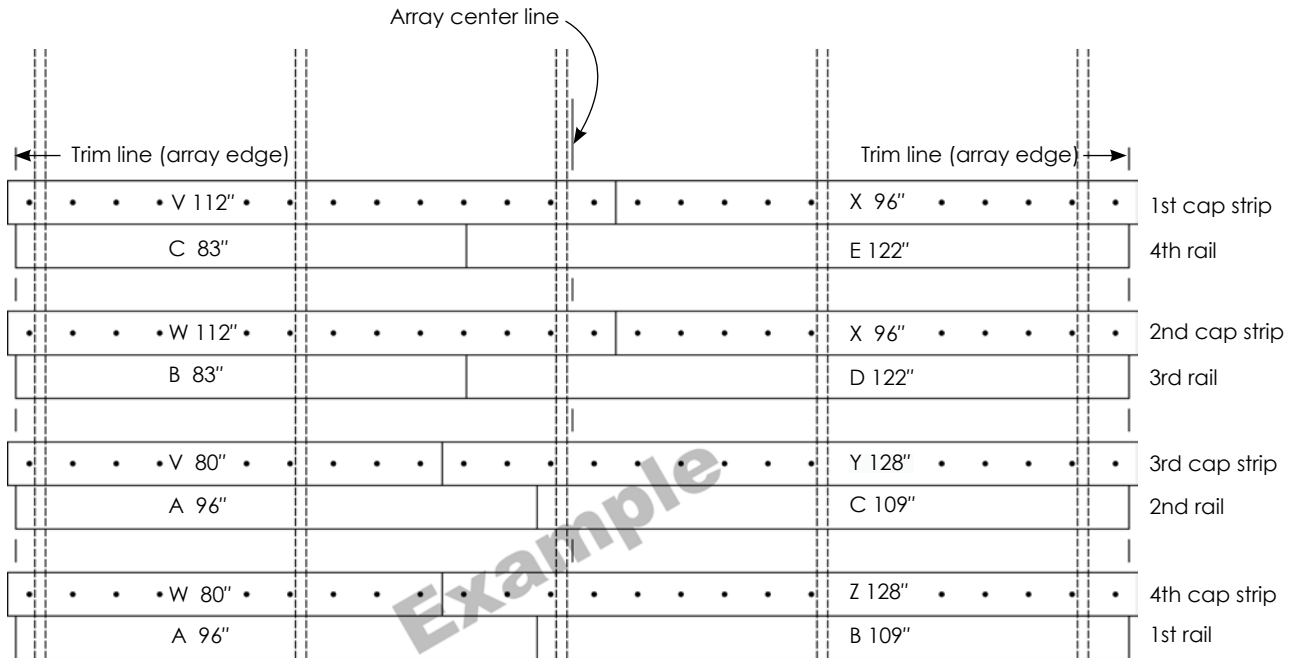

Usable remainder: D, 70"; E, 70"; Y, 64"; Z, 64"

## 6. Securing the first module:

Gather sufficient lengths of cap strip to cover the length of the first rail. For maximum visual appeal and material conservation see “Material planning for rails and cap strips” (p. 20).

Slide the first module into final position at one end of the array. Lay the remaining modules in the top row, leaving a gap about a foot wide between the first and second modules (Fig. 13).

The temporary gap allows the installer to place one of his feet between modules. He can access the section of the cap strip he needs to secure while leaning toward the peak of the roof. For the time being, the last module may overhang the rail by up to one third its width.

Attach the end of the cap strip with the cap strip screws (Fig. 13, inset), so that the upper end of the first module is secure.

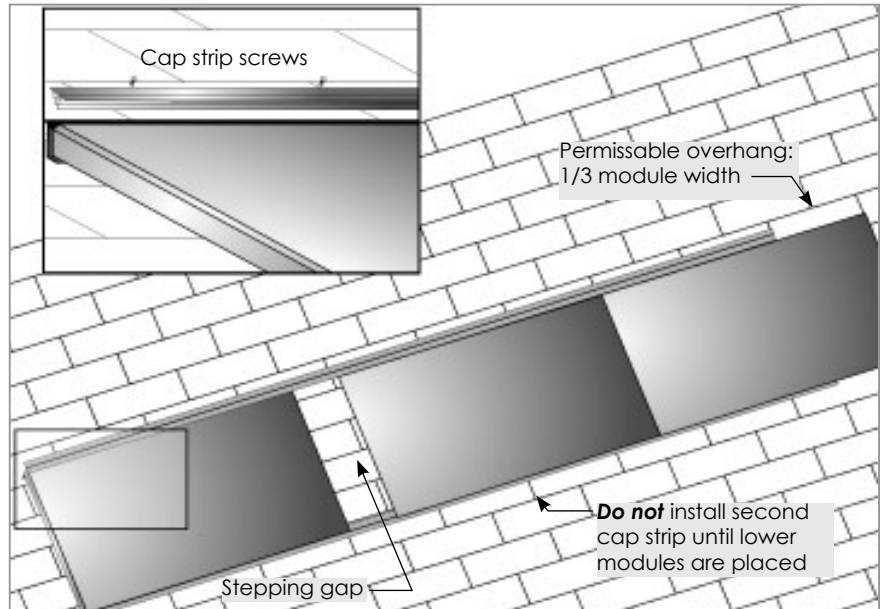





Figure 13. Begin cap strip installation.

 **The structural integrity of your array requires that cap strip screws fully engage the threaded rail. Use the cap strip screws supplied with your cap strips. Any substitute screws must be 1/4-20 Type F thread cutting (18-8 stainless steel) and the correct length.**

 **Every cap strip segment must have a cap strip screw 4 inches or less from each end. If the nearest predrilled hole falls more than 4 inches from any end, drill a 1/4-inch hole 2 inches from the end and install an additional screw.**

 **Wherever it is necessary to make a new cap strip hole, drill a 1/4-inch hole before installing the cap strip screw.**

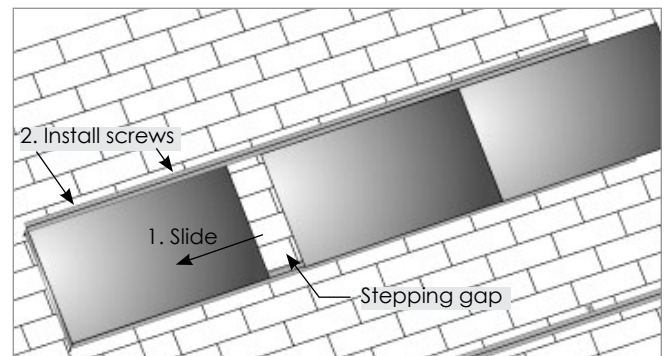

Figure 14. Position and secure modules one by one.

## 7. Installing the remaining modules in the top row:

Slide the next module into final position and install the screws to secure it (Fig. 14). For a neat installation, use cable ties to attach excess wiring to the rail beneath the flanges. Unirac’s cable ties can be attached to the SunFrame rail by drilling a 1/4-inch hole in the rail and pushing the end of the tie into the hole.

Continue the process until all modules in the top row are in final place and secured from the top. When complete, every prepunched hole in the cap strip will be secured by a screw, and the top end of the first row of modules will be secure.

## 8. Installing the remaining modules row by row:

Repeat Steps 6 and 7 for the remaining rows (Fig. 15). Each subsequent cap strip will secure the tops to the modules being installed and the bottoms of the modules in the row above.

Place the final cap strip in the lowest rail, securing the bottom of the lowest module row.

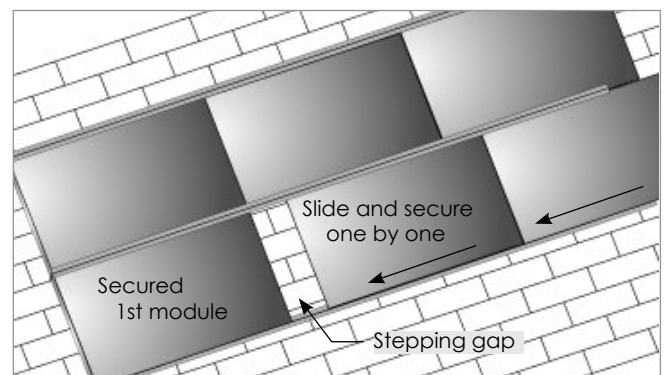

Figure 15. As modules slide into place, the stepping gap shifts, always allowing access to the section of cap strip being secured.

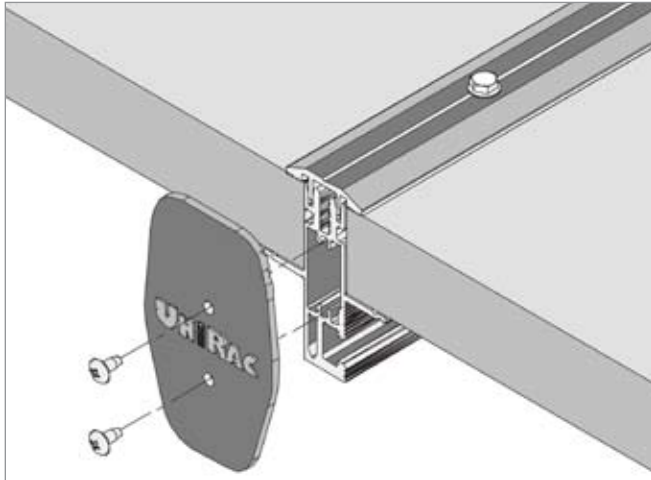

Figure 16. End cap installation.

**9. Installing the end caps:**

Attach the end caps to the ends of the rails by securing with the truss head sheet metal screws provided (Fig. 16).

**Table 4: PV module, cap strip, and cap strip screw compatibility**

To ensure code compliance and a structurally sound array, cap strip sizes and cap strip screw lengths must be compatible with the PV modules in your installation. All cap strip screws must be ¼-20 Type F thread cutting (18-8 stainless steel).

Module thickness or type		Cap strip cross section	Cap strip size	Required screw length (inches)
inches	mm			
1.34–1.42	34–36		C	¾"
1.50–1.57	38–40		D	¾"
1.77–1.85	45–47		F	1"
1.93–2.01	49–51		E	1 ¼"
Sharp lipped modules			G	1"
Sanyo lipped modules			H	¾"

## Frequently asked questions about standoffs and roof variations

### How high above the roof is a SunFrame array?

The answer depends on the orientation of your L-feet and the length of your standoffs, if used. See the illustration appropriate to your installation.

### How can I seal the roof penetration required when standoffs are lagged below the roofing material?

Many types and brands of flashing can be used with SunFrame. Unirac offers an Oatey® “No-Calk” flashings for its steel standoffs and Oatey® or Unirac flashings for its aluminum two-piece standoffs. See our SunFrame Pro-Pak Price List.

### How do I attach SunFrame to a standing-seam metal roof?

Unirac is pleased to present ACECLAMP® JR, our latest solution for mounting rails to a standing seam roof. Innovative and affordable, ACECLAMP JR is designed to provide a superior, non-penetrating method for attaching solar modules to any of the popular seamed metal roofing systems.

When compared to other solutions, this innovative two piece design has only one bolt with a “top down” clamping mechanism that installs faster than any other standing seam attachment on the market today.

ACECLAMP JR with the 3/8” (10mm) mounting connection can be used to secure any SunFrame solution to ACECLAMP JR. Rail attachments should be ordered separately.

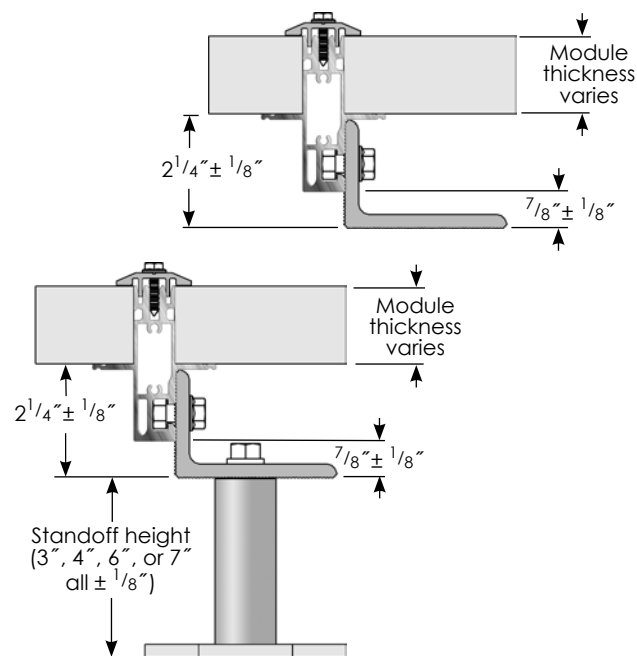
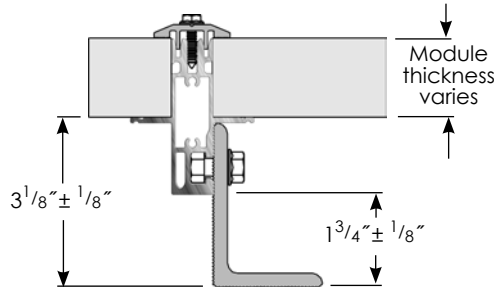

---

## 10 year limited Product Warranty, 5 year limited Finish Warranty

---

Unirac, Inc., warrants to the original purchaser (“Purchaser”) of product(s) that it manufactures (“Product”) at the original installation site that the Product shall be free from defects in material and workmanship for a period of ten (10) years, except for the anodized finish, which finish shall be free from visible peeling, or cracking or chalking under normal atmospheric conditions for a period of five (5) years, from the earlier of 1) the date the installation of the Product is completed, or 2) 30 days after the purchase of the Product by the original Purchaser (“Finish Warranty”).

The Finish Warranty does not apply to any foreign residue deposited on the finish. All installations in corrosive atmospheric conditions are excluded. The Finish Warranty is VOID if the

practices specified by AAMA 609 & 610-02 – “Cleaning and Maintenance for Architecturally Finished Aluminum” ([www.aamanet.org](http://www.aamanet.org)) are not followed by Purchaser. This Warranty does not cover damage to the Product that occurs during its shipment, storage, or installation.

This Warranty shall be VOID if installation of the Product is not performed in accordance with Unirac’s written installation instructions, or if the Product has been modified, repaired, or reworked in a manner not previously authorized by Unirac IN WRITING, or if the Product is installed in an environment for which it was not designed. Unirac shall not be liable for consequential, contingent or incidental damages arising out of the use of the Product by Purchaser under any circumstances.

If within the specified Warranty periods the Product shall be reasonably proven to be defective, then Unirac shall repair or replace the defective Product, or any part thereof, in Unirac’s sole discretion. Such repair or replacement shall completely satisfy and discharge all of Unirac’s liability with respect to this limited Warranty. Under no circumstances shall Unirac be liable for special, indirect or consequential damages arising out of or related to use by Purchaser of the Product.

Manufacturers of related items, such as PV modules and flashings, may provide written warranties of their own. Unirac’s limited Warranty covers only its Product, and not any related items.