



## Diesel Product Line

208-600 Volt

**BSJD415KWS**

60 Hz / 1800 RPM

**415 kWe**

Standby

## Ratings

	208V	240V	480V	600V
<b>Phase</b>	3	3	3	3
<b>PF</b>	0.8	0.8	0.8	0.8
<b>Hz</b>	60	60	60	60
<b>Generator Model</b>	572RSL4025	572RSL4025	433CSL6220	572RSS4270
<b>Connection</b>	12 LEAD WYE	12 LEAD DELTA	12 LEAD WYE	4 LEAD WYE
<b>Standby (Stationary Applications Only)</b>				
<b>kWe</b>	415	415	415	415
<b>AMPS</b>	1442	1249	625	500
<b>Temp Rise</b>	130°C / 27°C	130°C / 27°C	130°C / 27°C	130°C / 27°C

## Standard Equipment

### Engine

- ▶ Radiator Cooled Unit Mounted (50°C)
- ▶ Blower Fan & Fan Drive
- ▶ Starter & Alternator
- ▶ Oil Pump & Filter
- ▶ Oil Drain Extension w/Valve
- ▶ Governor - Electronic Isochronous
- ▶ 24V Battery System & Cables
- ▶ Air Cleaner (Dry Single Stage)
- ▶ Flexible Fuel Connector
- ▶ EPA Certified - Tier 3

### Listing Certifications

- ▶ UL 2200 Listed
- ▶ cUL Listed
- ▶ CSA Certified
- ▶ Seismic Certified to IBC 2012

### Generator

- ▶ Brushless Single Bearing
- ▶ Automatic Voltage Regulator
- ▶ ± 1% Voltage Regulation
- ▶ 4 Pole, Rotating Field
- ▶ 130°C Standby Temperature Rise
- ▶ 100% of Rated Load - One Step
- ▶ 5% Maximum Harmonic Content
- ▶ NEMA MG 1, IEEE and ANSI Standards Compliance for Temperature Rise

### Additional

- ▶ Microprocessor Based Digital Control
- ▶ Interface Connection Box
- ▶ Control Panel Mounted in NEMA 12 Enclosure
- ▶ Base - Structural Steel
- ▶ Main Line Circuit Breaker Mounted & Wired
- ▶ Critical Grade Silencer Mounted (Standby)
- ▶ Battery Charger 24V 5 Amp
- ▶ Jacket Water Heater -20°F 4000W 240V w/Isolation Valves
- ▶ Vibration Isolation Mounts Pad Type
- ▶ Radiator Duct Flange (OPU Only)
- ▶ Single Source Supplier
- ▶ 2YR / 2000HR Standby Warranty
- ▶ Standard Colors - White / Tan / Gray

# Diesel Product Line

**BSJD415KWS**  
**415 kWe**



**POWERDAK**  
POWER PRODUCTS, LLC

## Application Data

Engine			
Manufacturer:	John Deere	Displacement - Cu. In. (lit):	824 (13.5)
Model:	6135HFG84	Bore - in. (cm) x Stroke - in. (cm):	5.20 (13.2) x 6.50 (16.5)
Type:	4-Cycle	Compression Ratio:	16.0:1
Aspiration:	Turbo Charged, CAC	Rated RPM:	1800
Cylinder Arrangement:	6 Cylinder Inline	Max HP Stby (kWm):	617 (460)

Exhaust System	Standby
Gas Temp. (Stack): °F (°C)	981 (527)
Gas Volume at Stack Temp: CFM (m³/min)	2,606 (73.8)
Maximum Allowable Exhaust Restriction: in. H <sub>2</sub> O (kPa)	30.0 (7.50)

Cooling System	
Ambient Capacity of Radiator: °F (°C)	122 (50.0)
Maximum Allowable Static Pressure on Rad. Exhaust: in. H <sub>2</sub> O (kPa)	0.50 (0.12)
Water Pump Flow Rate: GPM (lit/min)	106 (401)
Heat Rejection to Coolant: BTUM (kW)	11,839 (207)
Heat Rejection to CAC: BTUM (kW)	5,350 (93.6)
Heat Radiated to Ambient: BTUM (kW)	3,543 (62.0)

Air Requirements	
Aspirating: CFM (m³/min)	996 (28.2)
Air Flow Required for Rad. Cooled Unit: CFM (m³/min)	24,455 (692)
Air Flow Required for Heat Exchanger/Rem. Rad. CFM (m³/min)	Consult Factory For Remote Cooled Applications

Fuel Consumption	
At 100% of Power Rating: gal/hr (lit/hr)	29.2 (110)
At 75% of Power Rating: gal/hr (lit/hr)	23.9 (90.5)
At 50% of Power Rating: gal/hr (lit/hr)	16.8 (63.4)

Fluids Capacity	
Total Oil System: gal (lit)	15.9 (60.0)
Engine Jacket Water Capacity: gal (lit)	4.76 (18.0)
System Coolant Capacity: gal (lit)	23.0 (87.1)

### Deration Factors

Rated Power is available up to 10,000 ft (3,048 m) at ambient temperatures to 122°F (50°C) standby.  
Consult factory for site conditions above these parameters.

# Diesel Product Line

**BSJD415KWS**  
**415 kWe**



**POWERDAK**  
POWER PRODUCTS, LLC

## DGC-2020 Control Panel

### Standard Features

- ▶ Digital Metering
- ▶ Engine Parameters
- ▶ Generator Protection Functions
- ▶ Engine Protection
- ▶ CAN Bus ECU Communications
- ▶ Windows-Based Software
- ▶ Multilingual Capability
- ▶ Remote Communications to RDP-110 Remote Annunciator
- ▶ 16 Programmable Contact Inputs
- ▶ Up to 15 Contact Outputs (7 standard)
- ▶ UL Recognized, CSA Certified, CE Approved
- ▶ Event Recording
- ▶ IP 54 Front Panel Rating with Integrated Gasket
- ▶ NFPA 110 Level 1 Compatible

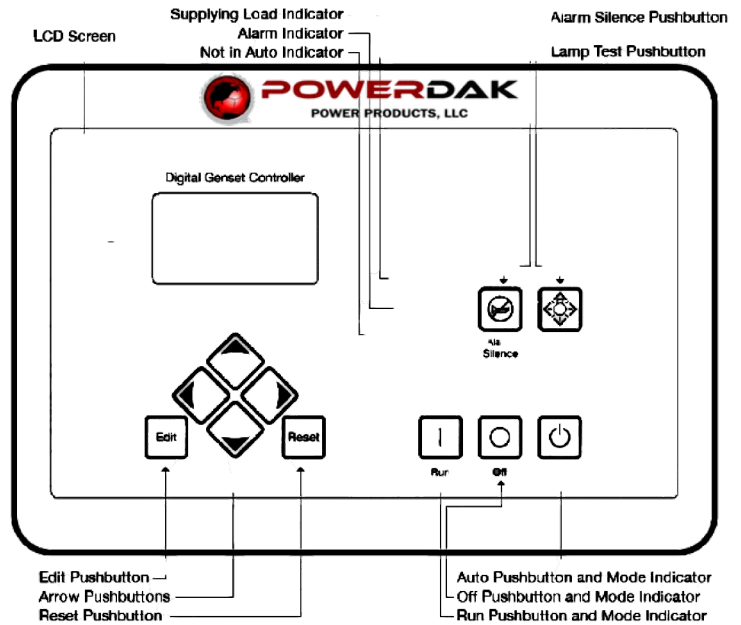

## Weights / Dimensions / Sound Data

	L x W x H	Weight lbs
<b>OPU</b>	140 x 66 x 85 in	8,050
<b>Level 1</b>	140 x 66 x 112 in	9,600
<b>Level 2</b>	140 x 66 x 112 in	9,675
<b>Level 3</b>	195 x 66 x 112 in	10,125

Please allow 6-12 inches for height of exhaust stack.

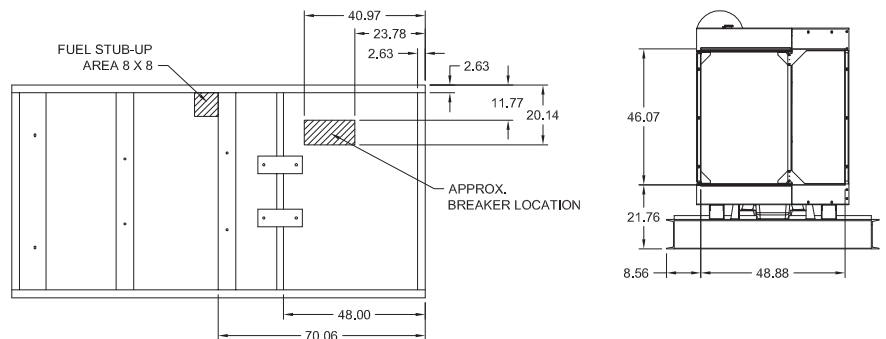

	No Load	Full Load
<b>OPU</b>	86 dBA	89 dBA
<b>Level 1</b>	83 dBA	85 dBA
<b>Level 2</b>	78 dBA	81 dBA
<b>Level 3</b>	70 dBA	73 dBA

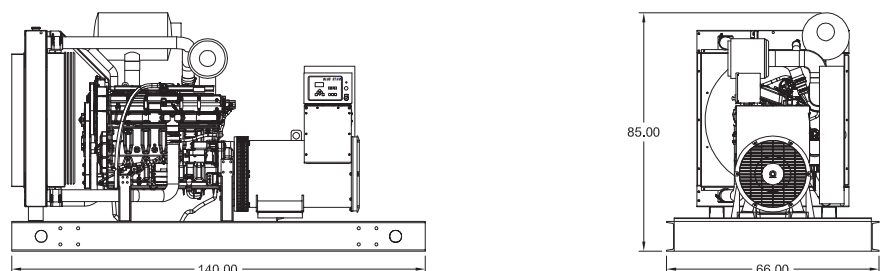

Drawings based on standard open power 480 volt standby generator. Lengths may vary with other voltages. Subject to change without notice. Sound data as measured at 23 feet (7 meters) in accordance with ISO 8528-10 at standby rating.

# Diesel Product Line

**BSJD415KWS**  
**415 kWe**



**POWERDAK**  
POWER PRODUCTS, LLC

## Enclosures (LEGACY)

Level 1 & 2 | Side View (Weather Proof)

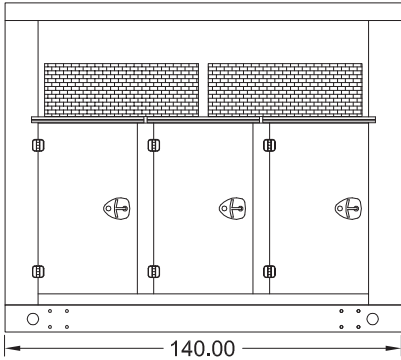

Level 3 | Side View (Sound Attenuated)

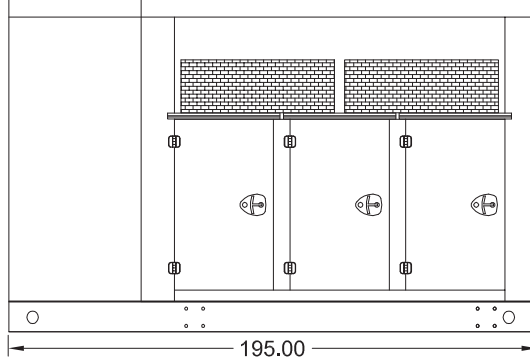

Level 1, 2 & 3 |

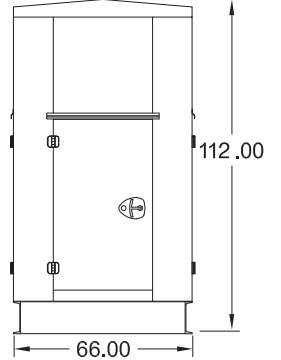

All enclosures are 150 MPH Wind Rated.

\*Enclosure height does not include exhaust stack.

Level 2 & 3 enclosures include sound attenuation foam.

Level 3 enclosure includes frontal sound & exhaust hood.

## Double Wall UL 142 Listed Fuel Tanks

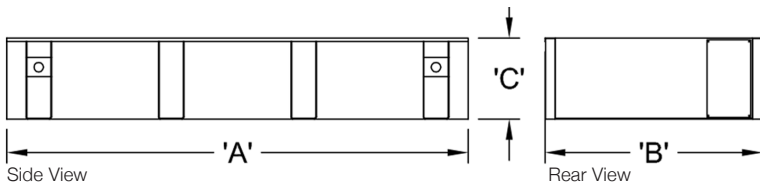
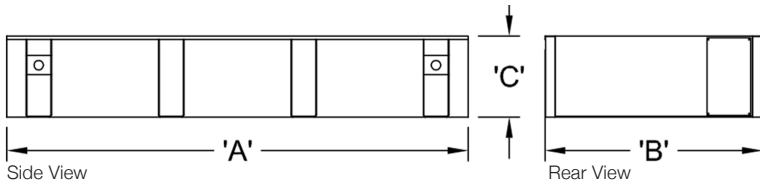

OPU / Level 1 / Level 2			
	24 Hour 710 Gallon	48 Hour 1420 Gallon	72 Hour 2130 Gallon
<b>A</b>	140.00	195.00	276.00
<b>B</b>	66.00	66.00	66.00
<b>C</b>	28.00	36.00	36.00

Level 3			
	24 Hour 710 Gallon	48 Hour 1420 Gallon	72 Hour 2130 Gallon
<b>A</b>	195.00	195.00	276.00
<b>B</b>	66.00	66.00	66.00
<b>C</b>	20.00	36.00	36.00

All specification sheet dimensions are represented in inches.

All enclosures and fuel tanks are based on the standard standby unit configuration. Any deviation can change dimensions. Materials and specifications subject to change without notice.

Powerdak Power Products - 3350 Jet Drive, Rapid City, South Dakota 57703 - 605.341.6160 Ext 1 - Fax 605.718.9998  
e-mail: [dave@dakgenerator.com](mailto:dave@dakgenerator.com)

American Owned



American Made