

## Features

### **GM 5.7L engine**

The 8 cylinder, overhead valve engine meets EPA/CARB emission regulations for LSI engines.

### **Stamford generator end**

Industrial grade generator ends.

### **Premium Square D circuit breakers**

Top quality breakers from a trusted brand.

### **Battery charger**

Factory installed 3 stage, 2 Amp battery charger.

### **Block heater**

In-line Kim Hotstart, 120V, block heater with thermostat.

### **DSE 7310**

Digital controller providing immediate performance information and safety shutdowns.

### **Galvanealed steel weather enclosure**

Conforms to NFPA noncombustible standards.

### **100% load tested**

You won't find statistical sampling here. We load test every generator before it leaves our facility.

## ***PACKAGED STANDBY SYSTEMS***

**80,000 Continuous Watts-LP  
90,000 Continuous Watts-NG**



## Optional Accessories

### **Generator strip heater**

Reduces condensation.

### **ASCO Automatic transfer switch**

Safely restore power to critical circuits.

### **Vapor fuel strainer**

Keep the fuel line free from debris that could cause damage to you generator.

### **Excitation boost system**

Provides excitation power for heavy loads or short circuits.

### **Battery charger upgrade**

Upgrade from the standard 2 Amp charger to a 5 Amp or 10 Amp with fail contact or 10 Amp NFPA compliant.

### **Battery heater upgrade**

Keeps battery warm for maximum power output at start-up.

### **NFPA 110 Level 1**

Factory installed, includes remote annunciator, DSE 10 Amp battery charger, and low coolant alarm.

### **WebNet**

Control your generator from your smartphone or computer.

### **LP liquid withdrawal**

Pulls liquid LP from tank and vaporizes on eng/gen set; allowing you to install smaller fuel lines and smaller fuel tanks.

MODEL NUMBER	OUTPUT	LP GAS			NATURAL GAS			CIRCUIT BREAKER
		VOLTS	WATTS	KVA	AMPS	WATTS	KVA	
PSS90-3	120/240 1-PH	80,000	80	333	90,000	90	375	350
PSS90-4	120/208 3-PH	80,000	100	278	90,000	112	312	300
PSS90-17	120/240 3-PH	80,000	100	240	90,000	112	270	300
PSS90-18	277/480 3-PH	80,000	100	120	90,000	112	135	150

Derating factors: **Temperature** - 1% for every 10°F above 77°F air inlet **Elevation** - 3% per 1,000 feet elevation above 1,000 feet above sea level.

## GENERATOR

SINGLE PHASE <sup>(1)</sup>	4 LEAD
3 PHASE <sup>(2)</sup>	12 LEAD
VOLTAGE REGULATION	+/-1%
VOLTAGE CONTROL	AS 440
TOTAL HARMONIC DISTORTION	<5%
TEMPERATURE RISE	125°/40°C
TYPE	4 POLE ROTATING FIELD
BRUSHED	NO
GENERATOR SPEED	1800 RPM
ROTOR	2/3 PITCH
WINDINGS	100% COPPER
STATOR WINDING	DOUBLE LAYER CONCENTRIC
EFFICIENCY PEAK	91%
COUPLING	FLEXIBLE DISC
BEARINGS	(1) MAINTENANCE FREE
TELEPHONE INTERFERENCE	<2%
INSULATION	CLASS H
GENERATOR WARRANTY <sup>(3)</sup>	1 YR/1000 HRS

NOTES: (1) Unity (1.0) power factor (2) 3-PH power factor 0.8 (3) For generator warranty information contact you local WINCO service center.

## FUEL

FUEL CONSUMPTION	AT FULL LOAD
LP	12.4 GAL/HR - 1,192,000 BTU/HR
NG	1,230 FT <sup>3</sup> /HR - 1,230,000 BTU/HR
INLET PRESSURE	4-6 OZ / 7"-11" WATER COLUMN
FUEL INLET SIZE	1 1/4"

## BATTERY<sup>(1)</sup>

DC SYSTEM VOLTAGE	12V
DC ALTERNATOR	ENGINE MOUNTED
BATTER RACK/ CABLE	INCLUDED
BATTERY CHARGER	STAGE 3 INCLUDED
REQUIRED BATTERY	GROUP 24 650 CCA

NOTES: (1) Battery not included

## ENGINE

BRAND	GM
MODEL	5.7L INDUSTRIAL
SPEED	1800 RPM
DISPLACEMENT	5.7L
CYLINDERS	8
LUBRICATION	FORCED W/ SPIN-ON FILTER
COOLING	LIQUID
BORE X STROKE	4 X 3.5"
IGNITION	ELECTRIC
GOVERNOR	ELECTRONIC
REGULATION	+/- 1 HZ STEADY STATE
EXHAUST	CRITICAL GRADE
EXHAUST OUTLET SIZE	3" AT MUFFLER
RECOMMENDED OIL	SAE 10W-30
OIL CAPACITY	5.5 QTS
LOW OIL PROTECTION	STANDARD
HIGH COOLANT TEMP PROTECTION	STANDARD
dba AT 7 METERS (FULL LOAD)	82
MOTOR STARTING (CODE G) <sup>(1)</sup>	30 HO
CARB/EPA APPROVED	YES
CSA APPROVED	YES
ENGINE WARRANTY <sup>(2)</sup>	3 YRS/3500 HRS

NOTES: (1) Code G capacitor motor. (2) Contact your local GM service center for engine warranty information.

## SHIPPING

DIMENSIONS (LxWxH)	102.5" x 36.45" x 51.9"
NET WEIGHT	2350 LBS
SHIPPING DIMENSIONS	117" x 49" x 67"
SHIP WEIGHT	2390 LBS
FREIGHT CLASS	70

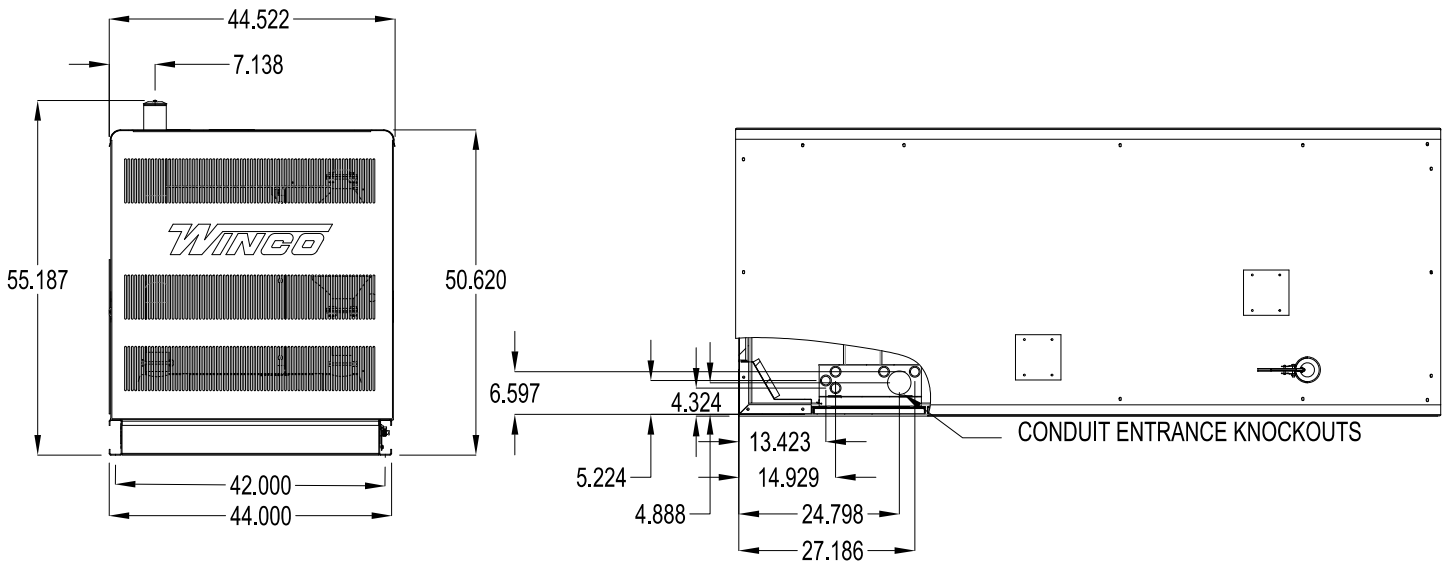
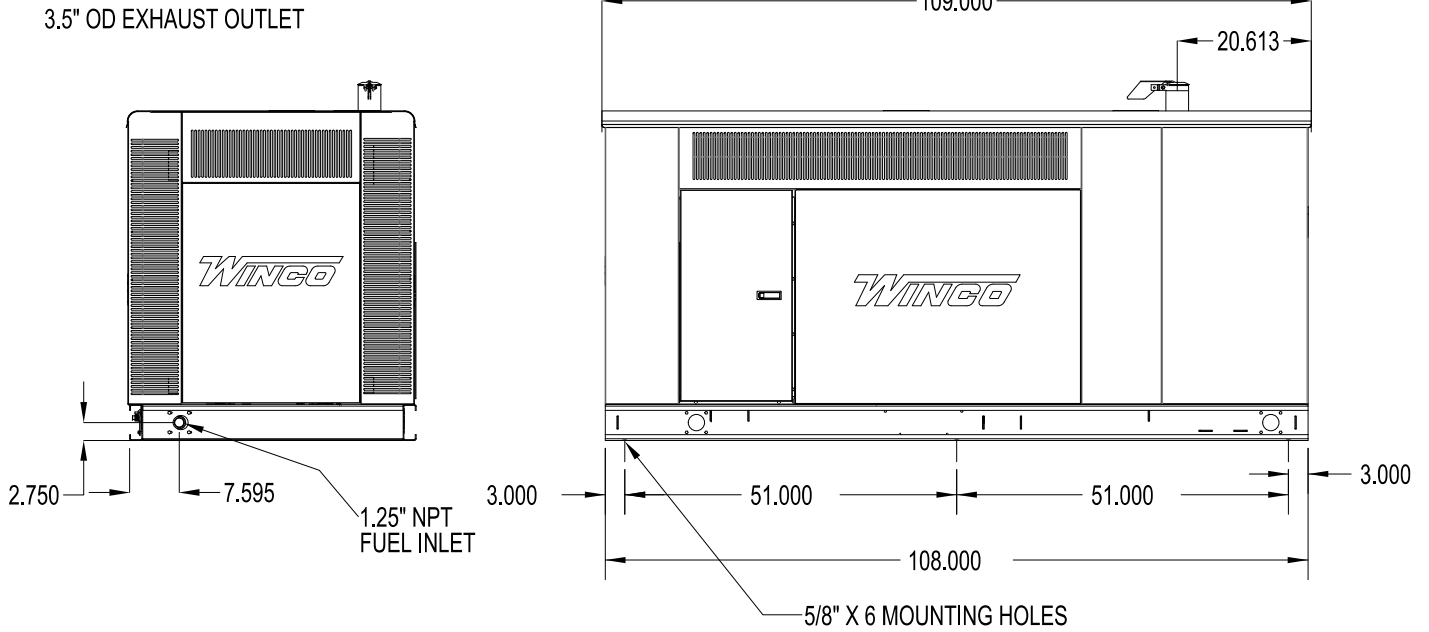

## DSE 7310 CONTROL FEATURES

ENGINE DISPLAY/PROTECTION	
ENGINE RPM	YES
LOW OIL PRESSURE	YES
HIGH COOLANT TEMPERATURE	YES
LOW COOLANT LEVEL	OPTIONAL
OVERSPEED	YES
UNDERSPEED	YES
OVERCRANK	YES
CHARGING ALTERNATOR FAILURE	YES
CAN ECU SHUTDOWN	YES
GENSET DISPLAY/PROTECTION	
VOLTAGE (L-N)	YES
VOLTAGE (L-L)	YES
OVERVOLTAGE	YES
UNDERVOLTAGE	YES
FREQUENCY	YES
OVERFREQUENCY	YES
UNDER FREQUENCY	YES
PHASE IMBALANCE	DISABLED
KW, KVA, KVARH DISPLAY	YES
KWH, KVAH, KVARH DISPLAY	YES
GENERATOR PHASE SEQUENCE	YES
EARTH CURRENT	OPTIONAL

ADDITIONAL DISPLAYS/PROTECTIONS	
EMERGENCY STOP	YES
BATTERY VOLTAGE	YES
BATTERY OVER/UNDER VOLTAGE	YES
BATTERY CHARGER FAILURE	OPTIONAL
COMMUNICATIONS	
USB CONNECTABLE	YES
RS232/RS485	YES
NFPA ANNUNCIATOR	10XDSE 2548 OPTIONAL
REMOTE DISPLAY PANEL	3XDSE 2510 OPTIONAL
ETHERNET/MODEM	OPTIONAL
ADDITIONAL FEATURES	
AUDIBLE ALARM	YES
ENGINE EXERCISER	YES
MAINTENANCE INTERVAL TIMER	3 EVENT
LOAD SHEDDING/DUMMY	OPTIONAL
CONFIGURABLE INPUTS	9-24 W/DSE 2130 OPTIONAL
CONFIGURABLE OUTPUTS	6-80 W/DSE 2751 OPTIONAL
EVENT LOG	250
ALTERNATIVE CONFIGURATIONS	3
UL/CSA LISTED	YES

